

Spot welding parameter

Steel, high alloyed, stainless

Nichtrostende austenitische Stähle nach DIN 17441

(z.B. X 5 CrNi 18 9 Werkstoffnummer 1.4301)

Electrode material: CuCoBe

Class A3/1 with DIN 44 759

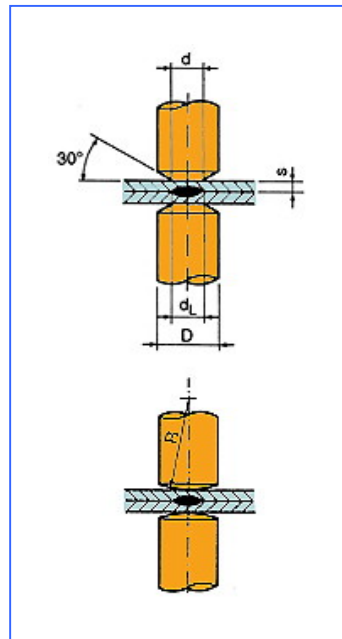

Adjustment values for single spot welding

Sheet thickness (mm) s	Nugget diameter (mm) dL	Electrode			Electrode force (kN) F	Current time welding (Per) ts	Welding current (kA) I2
		(mm) D	(mm) d	(mm) R			
0.50	3.5	16	4.0	75	1.8	4	6.0
0.75	4.5	16	4.5	75	3.0	5	6.8
1.00	5.0	16	5.0	75	4.0	7	7.5
1.25	5.5	20	5.5	75	5.0	8	8.3
1.50	6.0	20	6.0	75	6.5	10	9.0
2.00	7.0	20	7.0	100	9.0	13	10.5
2.50	8.0	25	8.0	100	12.0	16	12.0
3.00	8.5	25	8.5	100	15.0	19	13.5

Note:

- kegelförmige Elektroden für hohe Standmengen - ballige Elektroden für hohe Oberflächengüte
- bei abweichenden Linsendurchmessern und unterschiedlichen Blechstärken sind Elektrodengeometrie und Schweißparameter in Versuchen festzulegen.
- Gleichstrommaschinen erlauben breitere Einstellbereiche und damit eine höhere Schweißsicherheit.

Roller-seam welding parameter

Steel, high alloyed, stainless (Dichtnähte)

Nichtrostende austenitische Stähle nach DIN 17441

(z.B. X 5 CrNi 18 9 Werkstoffnummer 1.4301)

Electrode material: CuCoBe

Class A3/1 with DIN 44 759

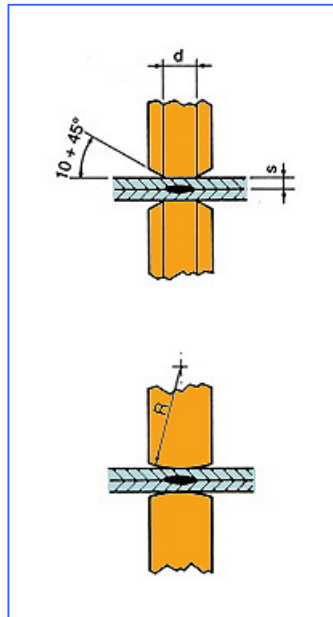

Adjustment values for welding with current programs

Sheet thickness (mm) s	Welding speed (m/min) v	Electrode roller		Electrode force (kN) F	Current time welding (Per) ts	Current pause time		Welding current (kA) I2
		(mm) d	(mm) R			(Per) tpmin	(Per) tpmax	
0.50	1.4	3.0	50	3.0	3	2	3	8.0
0.75	1.3	3.5	50	4.0	3	3	4	11.0
1.00	1.2	4.0	75	5.0	3	4	5	12.0
1.25	1.2	4.5	75	6.0	4	4	5	13.0
1.50	1.1	5.0	75	8.0	4	5	6	15.0
2.00	1.0	6.0	75	10.0	4	6	7	16.0
2.50	1.0	7.0	150	12.5	5	6	7	16.5
3.00	0.9	8.0	150	15.0	6	6	8	17.0

Note:

- kegelförmige Elektroden für hohe Standmengen
- ballige Elektroden für hohe Oberflächengüte