

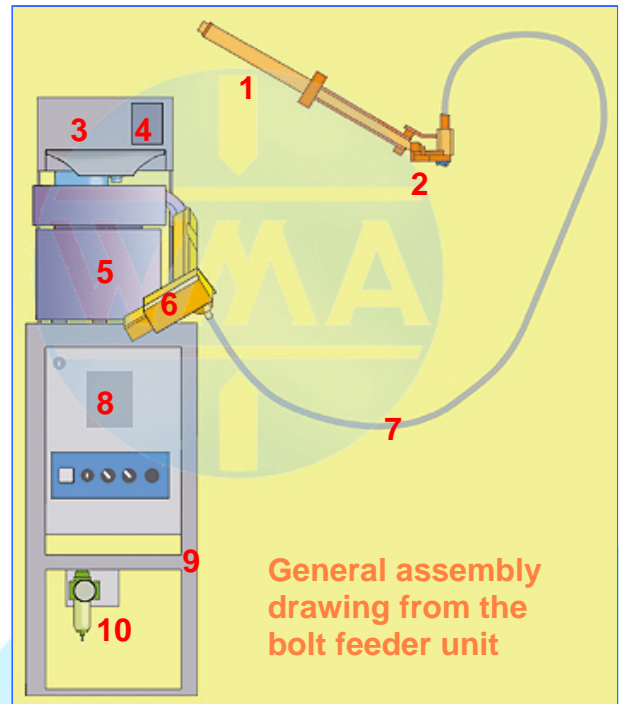

# Bolt feeder unit

Version: 01-2011

for threaded bolts, welding screws  
and special threaded bolts



- |                |                   |
|----------------|-------------------|
| 1 Feeder unit  | 6 Bolt separator  |
| 2 Chuck        | 7 Vinyl tube      |
| 3 Bulk hopper  | 8 Control box     |
| 4 Level switch | 9 Rack            |
| 5 Rotary bowl  | 10 Pressure gauge |

- for threaded studs and special threaded bolts
- High-speed feeding
- Selection capability: up to 60 bolts per min.
- Feeding stroke: 200 mm (standard)
- Feeding angle: 30° (standard)  
45° (optional)
- Power supply: 110 V / 50 Hz or 230 V / 50 Hz
- Control voltage: 24 V DC
- Air supply: 5 bar
- PLC: Siemens Logo



**Well-known companies use our feeders in their automated production.**

*Please, find convenient electrodes in chapter Electrodes for welding screws or bolts.*

We reserve the right to make changes which are in the interest of technical progress.

© by WMA Schmidt & Bittner GmbH, Baumwaide 23, D-74360 Illfeld-Auenstein, Tel. +49 7062 9066-0, Fax +49 7062 9066-20  
info@wma-sb.de or wma-sb@t-online.de, <http://www.wma-sb.de>

**Bolt feeder unit-1**



# Bolt feeder unit

Version: 01-2011

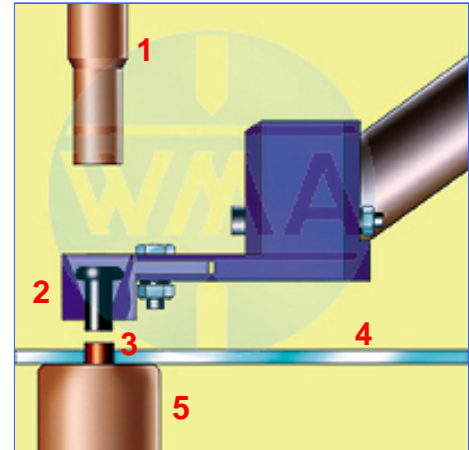
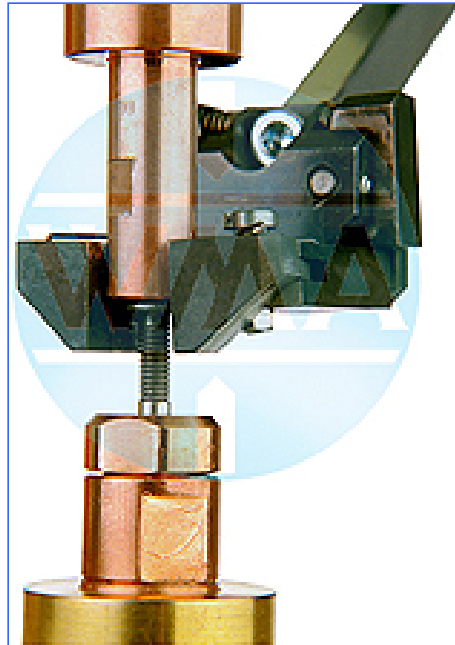

- 1 Upper electrode
- 2 Welding bolt in clamping jaws
- 3 Insulating bush
- 4 Work piece
- 5 Lower electrode

*Welding bolt fed to the welding electrode.*

## Options:

- Special designs are available, including direct connection of guide pin to the air cylinder in lower electrode, together with extend and retract position proximity switches and additional solenoid, which allow positive control of the guide pin location in the workpiece.
- Double-feeding is possible.
- A fabricated cover for noise control is available.
- The bulk hopper can be fitted with a level switch to indicate re-filling is required, when the feeder is used in automated cells.
- 300 mm stroke
- tube length up to 10m

We reserve the right to make changes which are in the interest of technical progress.

© by WMA Schmidt & Bittner GmbH, Baumwaide 23, D-74360 Illfeld-Auenstein, Tel. +49 7062 9066-0, Fax +49 7062 9066-20  
info@wma-sb.de or wma-sb@t-online.de, <http://www.wma-sb.de>

**Bolt feeder unit-2**