



Milling cutter 4000

Version: 01-2011

Pneumatically, hand-operated electrode milling cutter 4000

- zur mechanischen Nachbearbeitung from electrode caps on spot welding guns.
- Nachbearbeitung in nur 3 Sekunden (in current free status!)
- austauschbarer Fräskopf zur Bearbeitung rotationssymmetrischer Elektrodenkappen.

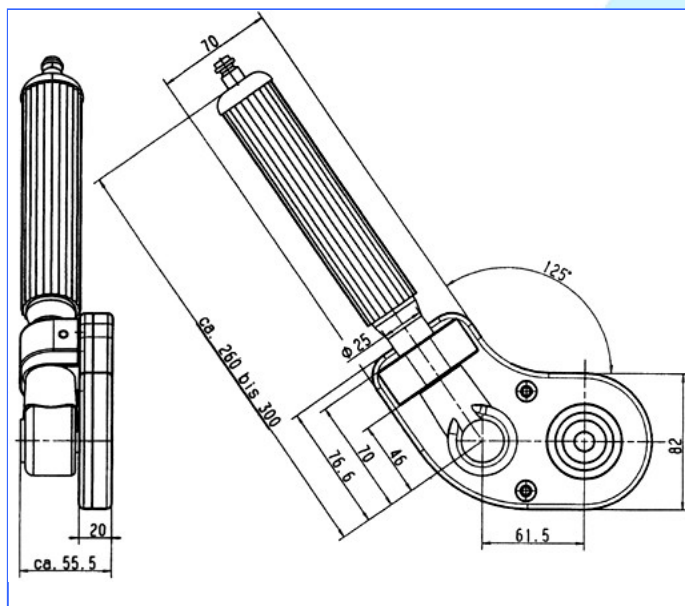
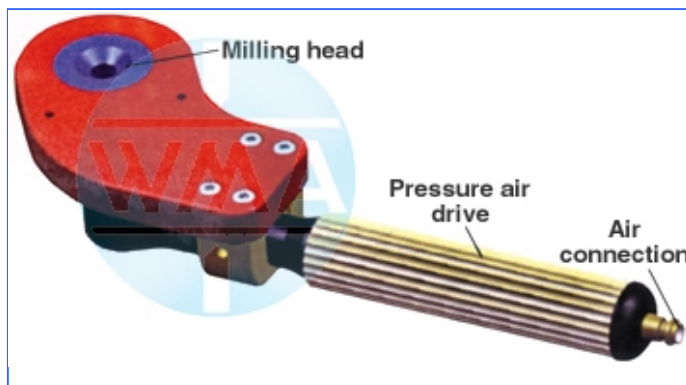

Max. electrode force	1.1-1.4 kN
Milling time: Start milling	3 x 5 s
Normal milling	1.5-5 s
Torque	90 Nm
Rotation speed	
Operating pressure	5.5-6.3 bar
Compressed air consumption	190 l/min
Weight	2.5 kg
Air connection	Plug nipple 1/4"

Order-number: XH2.010.005
Without milling head and knife! Specify electrode diameter and shape.

We reserve the right to make changes which are in the interest of technical progress.

© by WMA Schmidt & Bittner GmbH, Baumwaide 23, D-74360 Illfeld-Auenstein, Tel. +49 7062 9066-0, Fax +49 7062 9066-20
info@wma-sb.de or wma-sb@t-online.de, <http://www.wma-sb.de>

Milling cutter-1



Milling cutter 4000

Version: 01-2011

Design variations:

Screwable milling head	Screwable cutting plate Clampable cutting plate Clampable cutting plate (2x)	45 mm flange, 50 mm flange 45 mm flange, 50 mm flange 45 mm flange
Special screwable milling head	Clampable cutting plate	50 mm special flange
Bayonet milling head	Screwable cutting plate Clampable cutting plate (1 or 2x)	45 mm flange 45 mm flange
Special bayonet milling head	Clampable cutting plate	50 mm special flange
Special milling head	Clampable cutting plate	special flange
Gear wheel special milling head	Screwable cutting plate	
Electrode caps diameter	13 mm, 16 mm, 20 mm	
Integrated guidance of the electrode caps in the miller	without guidance, upper guidance, lower guidance, double-sided guidance	
Cam switch for rotation speed monitoring	without cam switch, one upper cam switch, two upper cam switches, one lower cam switch	

We reserve the right to make changes which are in the interest of technical progress.

© by WMA Schmidt & Bittner GmbH, Baumwaide 23, D-74360 Illfeld-Auenstein, Tel. +49 7062 9066-0, Fax +49 7062 9066-20
info@wma-sb.de or wma-sb@t-online.de, <http://www.wma-sb.de>

Milling cutter-2



Milling cutter 4000

Version: 01-2011

Information for assembly:

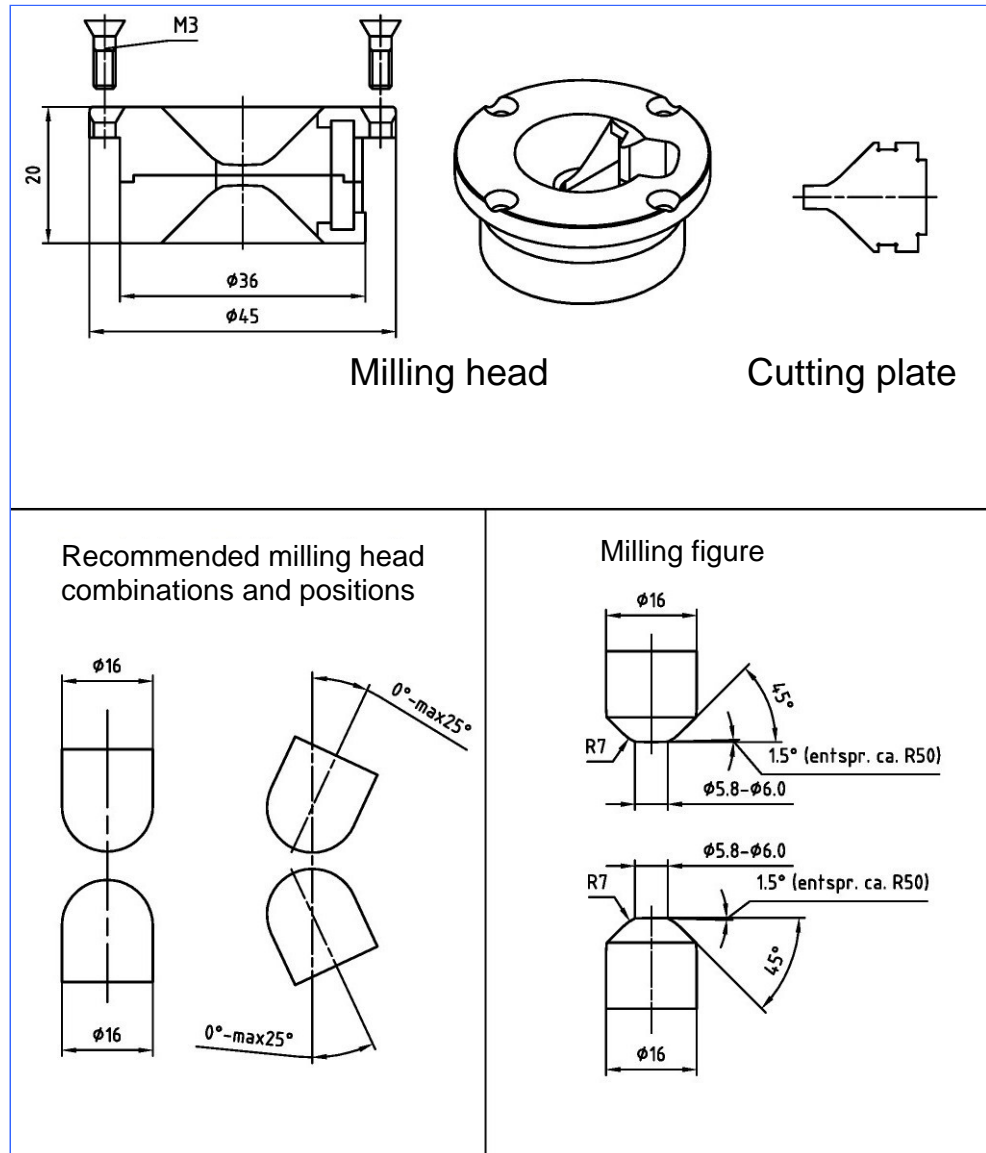

When order please specify electrode head shape and dimensions.

We reserve the right to make changes which are in the interest of technical progress.

© by WMA Schmidt & Bittner GmbH, Baumwaide 23, D-74360 Illfeld-Auenstein, Tel. +49 7062 9066-0, Fax +49 7062 9066-20
info@wma-sb.de or wma-sb@t-online.de, <http://www.wma-sb.de>

Milling cutter-3