



PMP 6-5/50-260

Version: 01-2011

Pneumatically operated, water cooled* stationary spot welding machines

- vertical arm spacing can be steplessly adjusted with ratchet
- electrode force can be regulated with a switch
- with a compressed air maintenance unit
- with main switch
- separately adjustable cooling water circuits with a flow and temperature display

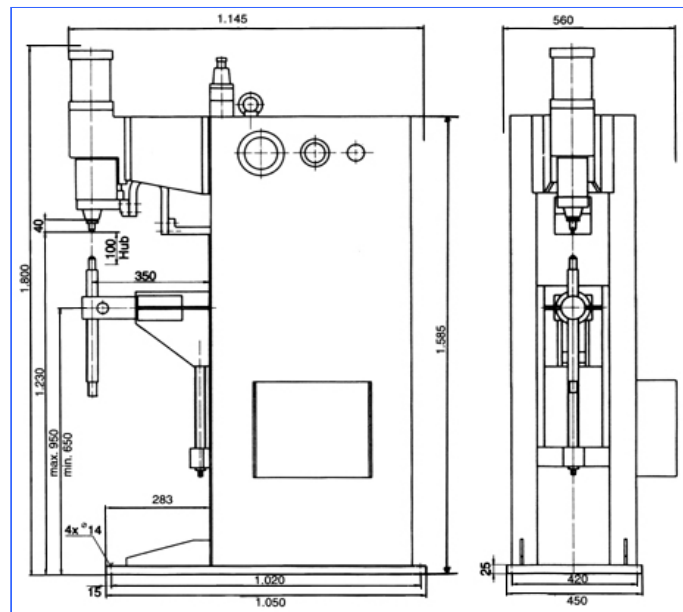

	PMP 6-5/	50	80	100	120	125	150	160
Welding performance*	mm	3 + 3	4 + 4	4 + 4		5 + 5	5 + 5	
Nom. capacity (at 50% ED)	kVA	50	80	100	120	125	150	160
Supply power	kVA	103	184	239		285	320	
Connection section	mm ²	35	70	95		120	185	
Fuse, delayed action	A	100	160	200		250	315	
max. welding current	kA	23.2	33.6	38.4		43.2	46.4	
Electrode force	daN	140-900	900	140-900	900	140-900	140-900	900
Depth of throat	mm	350	350	350	350	350	350	350
Electrode stroke	mm	100	100	100	100	100	100	100
Order-number	XNO.	122.C01	128.C01	130.C02	154.C01	131.C01	133.C01	134.C01

* The max. welding values quoted refer to sheet steel.

Standard design

Different welding controls can be used.

*This kit does not include a water chiller!

WMA is general distributor for NIMAK welding machines in Baden-Wuerttemberg.

We reserve the right to make changes which are in the interest of technical progress.

© by WMA Schmidt & Bittner GmbH, Baumwaide 23, D-74360 Ilfeld-Auenstein, Tel. +49 7062 9066-0, Fax +49 7062 9066-20
 info@wma-sb.de or wma-sb@t-online.de, <http://www.wma-sb.de>



PMP 6-5/50-260

Version: 01-2011

Mid frequency technology:

	PMP 6-5/	130MF	180MF	260MF**
Welding performance	mm			
Nom. capacity (at 50% ED)	kVA	130	180	260
Supply power	kVA			
Connection section	mm ²			
Fuse, delayed action	A			
max. welding current	kA			
Electrode force	daN	900	900	900
Depth of throat	mm	350	350	350
Electrode stroke	mm	100	100	100
Order-number	XNO.	132.C01	152.C01	136.C01

Standard design

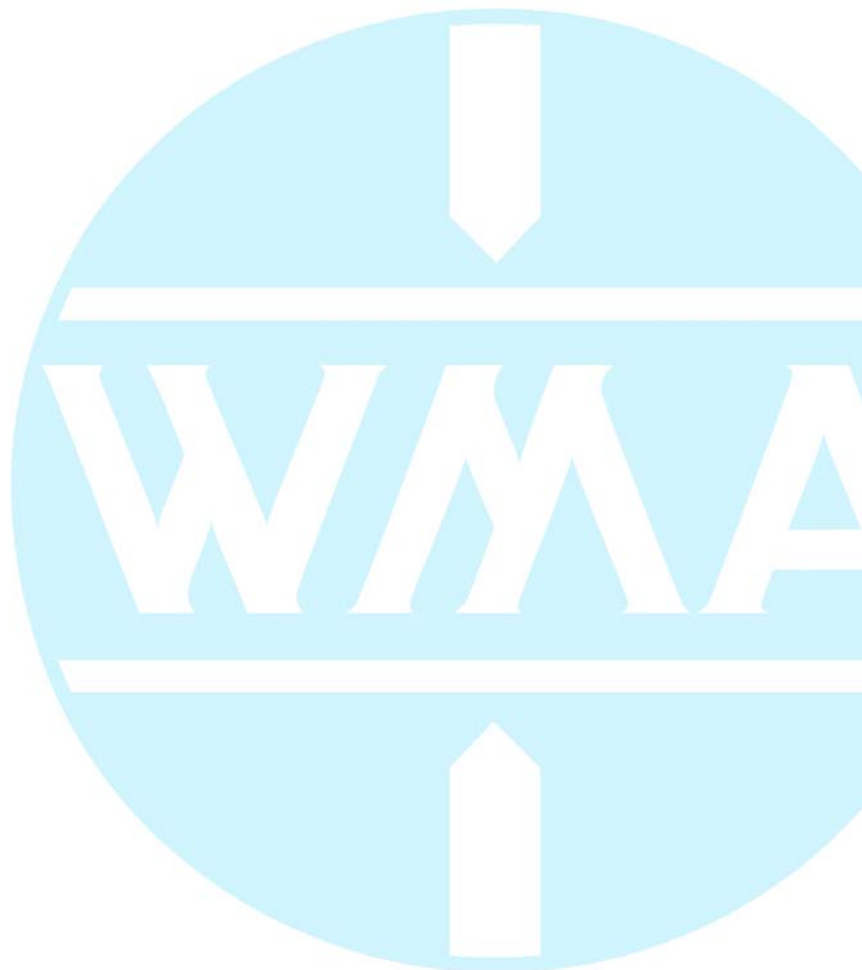

We reserve the right to make changes which are in the interest of technical progress.

© by WMA Schmidt & Bittner GmbH, Baumwaide 23, D-74360 Illfeld-Auenstein, Tel. +49 7062 9066-0, Fax +49 7062 9066-20
info@wma-sb.de or wma-sb@t-online.de, <http://www.wma-sb.de>

PMP6-2



PMP 6-5/50-260

Version: 01-2011

**Options,
the following devices and equipments can be built on:**

Flow controls

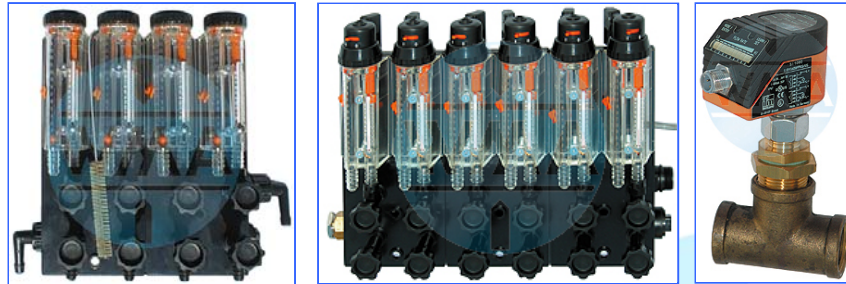

Measuring devices

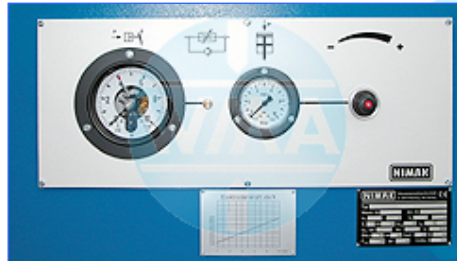

Water filters



Table height-adjustable
with threaded rod
and ratchet



Mounted
electrode holder

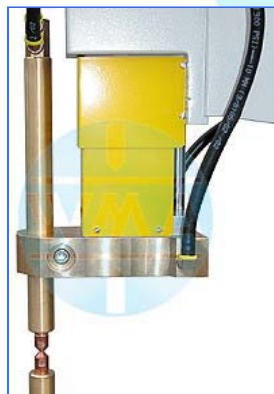

Supply cylinder
with hand wheel



Lower arm supports



We reserve the right to make changes which are in the interest of technical progress.

© by WMA Schmidt & Bittner GmbH, Baumwaide 23, D-74360 Illfeld-Auenstein, Tel. +49 7062 9066-0, Fax +49 7062 9066-20
info@wma-sb.de or wma-sb@t-online.de, <http://www.wma-sb.de>