



Cassette feeder units

Version: 01-2011

only for square nuts with DIN or ISO

For quick change between M5, M6, M8 or M10!

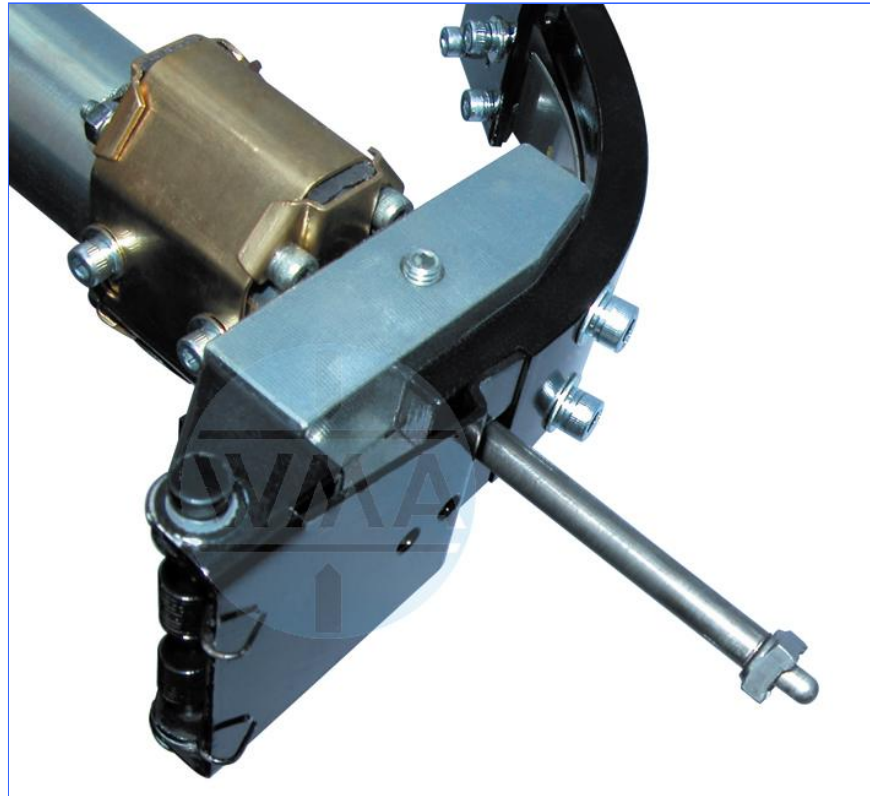

- for square nuts
- Vorratsbehälter mit Zuführtrutsche im Rotierförderer
- Rotierförderer mit Kassetten-Vereinzelner
- Selection capability: 40 up to 60 nuts per minute.
- PLC: Siemens Logo
- Delivery with 3 m vinyl tube



Well-known companies use our feeders in their automated production.

Please, find convenient electrodes in chapter Electrodes for welding screws or bolts.

We reserve the right to make changes which are in the interest of technical progress.

© by WMA Schmidt & Bittner GmbH, Baumwaide 23, D-74360 Illfeld-Auenstein, Tel. +49 7062 9066-0, Fax +49 7062 9066-20
info@wma-sb.de or wma-sb@t-online.de, <http://www.wma-sb.de>

Nut feeder unit-1



Cassette feeder units

Version: 01-2011



Basic device order-numbers:

M5 = XQ9.705.D00

M6 = XQ9.706.D00

M8 = XQ9.708.D00

M10 = XQ9.710.D00

Um von einer Muttergröße zur anderen zu wechseln, ist nur der Vereinzler auszuwechseln, und nicht das ganze Gerät!



Image shows the quick change of the cassette separator.

Cassette separator order-numbers:

for M5 = XQ9.705.001

for M6 = XQ9.706.001

for M8 = XQ9.708.001

for M10 = XQ9.710.001

We reserve the right to make changes which are in the interest of technical progress.

© by WMA Schmidt & Bittner GmbH, Baumwaide 23, D-74360 Iilsfeld-Auenstein, Tel. +49 7062 9066-0, Fax +49 7062 9066-20
info@wma-sb.de or wma-sb@t-online.de, <http://www.wma-sb.de>

Nut feeder unit-2



Cassette feeder units

Version: 01-2011



Feeder device mit Abfrage (Option)

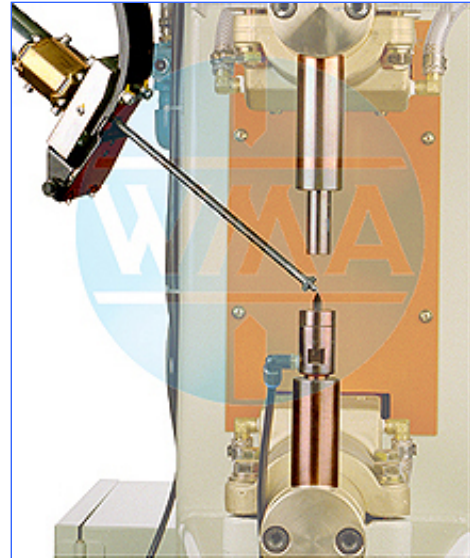

Feeding from the welding nut to the pilot pin from the lower electrode



Rütteltrommel mit angebaurem Vereinzeler

Options:

- The nut feeder units are available as vibratory- or rotary-types
- Double-feeding is possible
- A fabricated cover for noise control is available
- Abfrageeinheit am Zuführkopf anbaubar

We reserve the right to make changes which are in the interest of technical progress.

© by WMA Schmidt & Bittner GmbH, Baumwaide 23, D-74360 Illfeld-Auenstein, Tel. +49 7062 9066-0, Fax +49 7062 9066-20
info@wma-sb.de or wma-sb@t-online.de, <http://www.wma-sb.de>

Nut feeder unit-3



Cassette feeder units

Version: 01-2011

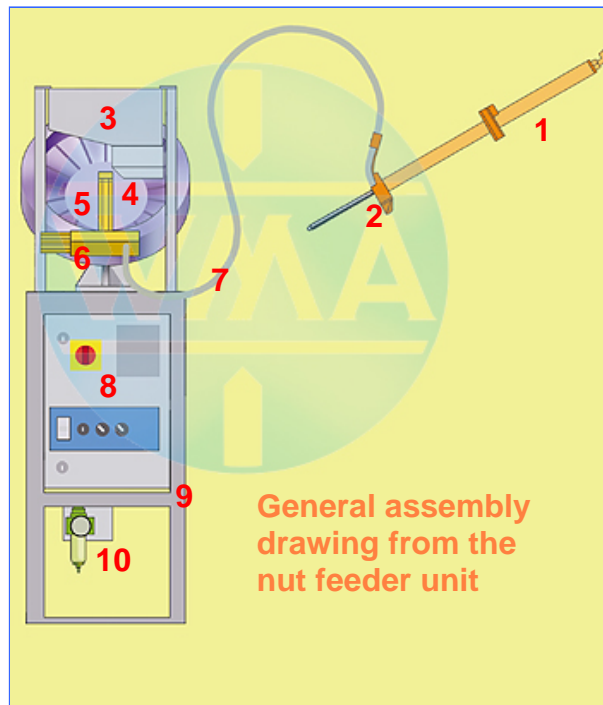

- 1 Feeder unit
- 2 Chuck
- 3 Bulk hopper
- 4 Level switch
- 5 Rotary bowl
- 6 Nut separator
- 7 Vinyl tube
- 8 Control box
- 9 Rack
- 10 Pressure gauge

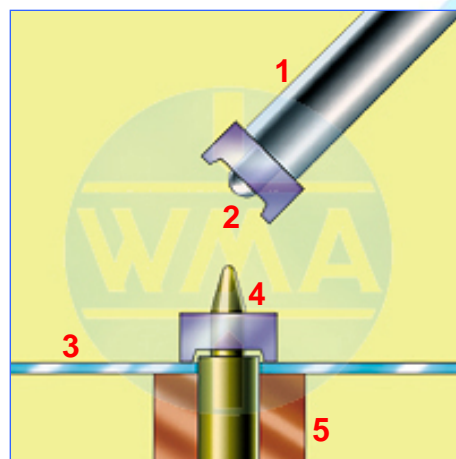

We reserve the right to make changes which are in the interest of technical progress.

© by WMA Schmidt & Bittner GmbH, Baumwaide 23, D-74360 Illfeld-Auenstein, Tel. +49 7062 9066-0, Fax +49 7062 9066-20
info@wma-sb.de or wma-sb@t-online.de, <http://www.wma-sb.de>

Nut feeder unit-4



Cassette feeder units

Version: 01-2011

Optional monitoring devices

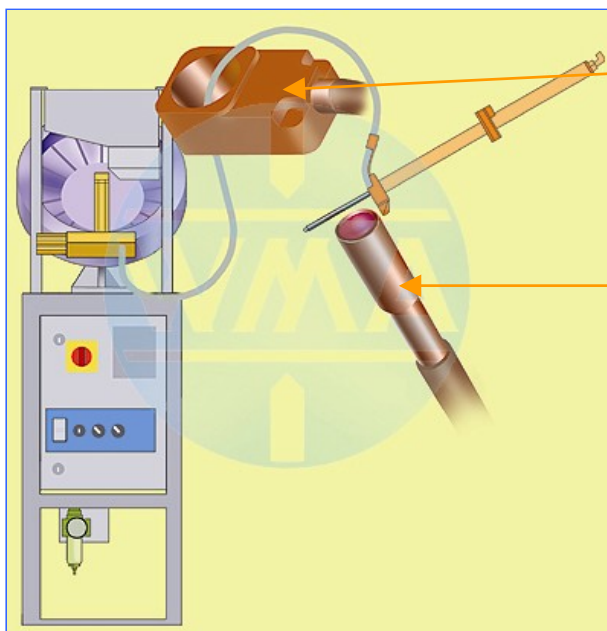

1 Ring sensor XQ9.500.007

überwacht, ob die Mutter erfolgreich durch den Schlauch geblasen wurde.

2 Inductive sensor XQ9.500.008

stellt fest, ob eine Mutter an der Zuführung bereitsteht.

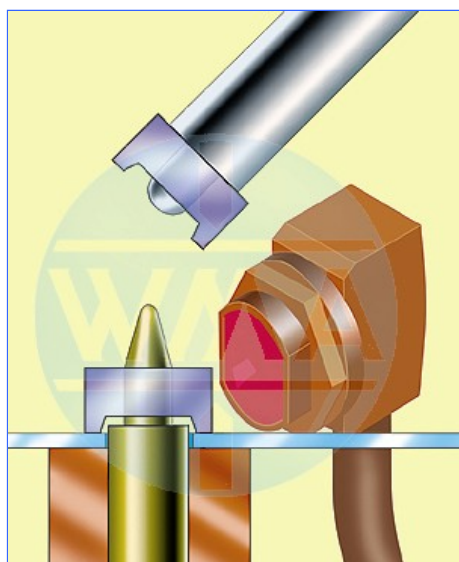

3 Laser reflexion detector XQ9.500.009

überprüft, ob das Bauteil bzw. die Mutter zum Schweißen bereitliegen.