



# Welding cylinder

with ground plate

Version: 2011-01

unilateral air connection,  
double-stage pressurized

undamped

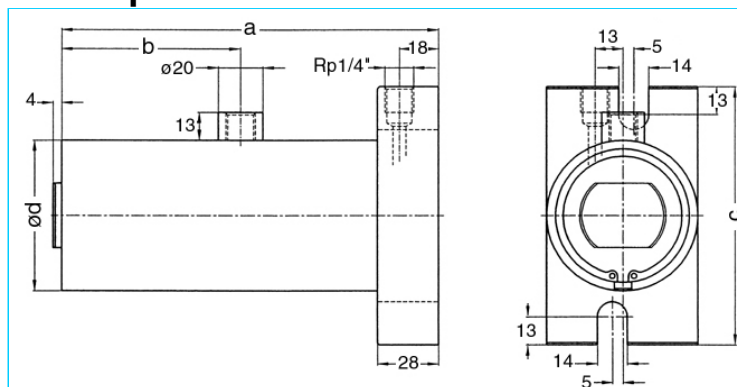

## Nominal size 038

Stroke	a	b	c	d	Force*	Order-number
36	173	82	98	48	0.2 kN	101.110.121.038.036.
50	201	96	98	48	0.2 kN	101.110.121.038.050.
65	231	111	98	48	0.2 kN	101.110.121.038.065.
80	261	126	98	48	0.2 kN	101.110.121.038.080.
100	301	146	98	48	0.2 kN	101.110.121.038.100.
130	361	176	98	48	0.2 kN	101.110.121.038.130.
150	401	196	98	48	0.2 kN	101.110.121.038.150.

\*at 1 bar pressure

## Nominal size 044

Stroke	a	b	c	d	Force*	Order-number
36	173	82	105	55	0.28 kN	101.110.121.044.036.
50	201	96	105	55	0.28 kN	101.110.121.044.050.
65	231	111	105	55	0.28 kN	101.110.121.044.065.
80	261	126	105	55	0.28 kN	101.110.121.044.080.
100	301	146	105	55	0.28 kN	101.110.121.044.100.
130	361	176	105	55	0.28 kN	101.110.121.044.130.
150	401	196	105	55	0.28 kN	101.110.121.044.150.

\*at 1 bar pressure

## Nominal size 058

Stroke	a	b	c	d	Force*	Order-number
36	173	82	120	70	0.5 kN	101.110.121.058.036.
50	201	96	120	70	0.5 kN	101.110.121.058.050.
65	231	111	120	70	0.5 kN	101.110.121.058.065.
80	261	126	120	70	0.5 kN	101.110.121.058.080.
100	301	146	120	70	0.5 kN	101.110.121.058.100.
130	361	176	120	70	0.5 kN	101.110.121.058.130.
150	401	196	120	70	0.5 kN	101.110.121.058.150.

\*at 1 bar pressure

**Complete the Order-number:**

Example: 101.110.121.058.050.??? **No. Force connection (S.6)?? No. Cylinder rod (S.7)!**

We reserve the right to make changes which are in the interest of technical progress.

© by WMA Schmidt & Bittner GmbH, Baumwaide 23, D-74360 Ilfeld-Auenstein, Tel. +49 7062 9066-0, Fax +49 7062 9066-20

info@wma-sb.de or wma-sb@t-online.de, <http://www.wma-sb.de>

Cylinder-Ground plate-1



# Welding cylinder

with ground plate

Version: 2011-01

unilateral air connection,  
double-stage pressurized

end position damped

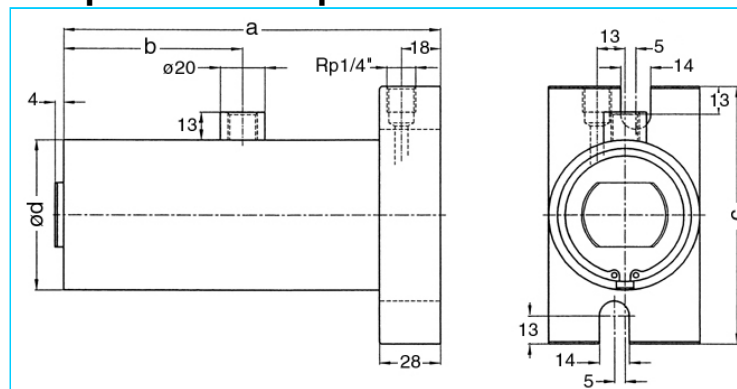

## Nominal size 044

Stroke	a	b	c	d	Force*	Order-number
36	201	96	105	55	0.28 kN	101.110.122.044.036.
50	231	111	105	55	0.28 kN	101.110.122.044.050.
65	261	126	105	55	0.28 kN	101.110.122.044.065.
80	301	146	105	55	0.28 kN	101.110.122.044.080.
100	361	176	105	55	0.28 kN	101.110.122.044.100.
130	401	196	105	55	0.28 kN	101.110.122.044.130.

\*at 1 bar pressure

## Nominal size 058

Stroke	a	b	c	d	Force*	Order-number
36	201	96	120	70	0.5 kN	101.110.122.058.036.
50	231	111	120	70	0.5 kN	101.110.122.058.050.
65	261	126	120	70	0.5 kN	101.110.122.058.065.
80	301	146	120	70	0.5 kN	101.110.122.058.080.
100	361	176	120	70	0.5 kN	101.110.122.058.100.
130	401	196	120	70	0.5 kN	101.110.122.058.130.

\*at 1 bar pressure

**Complete the Order-number:**

Example: 101.110.122.044.050.??? **No. Force connection (S.6)?? No. Cylinder rod (S.7)!**

We reserve the right to make changes which are in the interest of technical progress.

© by WMA Schmidt & Bittner GmbH, Baumwaide 23, D-74360 Illfeld-Auenstein, Tel. +49 7062 9066-0, Fax +49 7062 9066-20

info@wma-sb.de or wma-sb@t-online.de, <http://www.wma-sb.de>

Cylinder-Ground plate-2



# Welding cylinder

with ground plate

Version: 2011-01

unilateral air connection,  
double-stage pressurized

damped independent of stroke

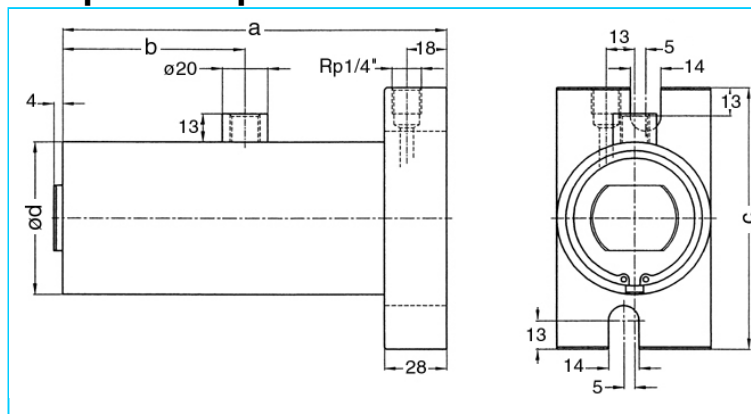

## Nominal size 044

Stroke	a	b	c	d	Force*	Order-number
36	173	82	105	55	0.28 kN	101.110.123.044.036.
50	201	96	105	55	0.28 kN	101.110.123.044.050.
65	231	111	105	55	0.28 kN	101.110.123.044.065.
80	261	126	105	55	0.28 kN	101.110.123.044.080.
100	301	146	105	55	0.28 kN	101.110.123.044.100.
130	361	176	105	55	0.28 kN	101.110.123.044.130.
150	401	196	105	55	0.28 kN	101.110.123.044.150.

\*at 1 bar pressure

## Nominal size 058

Stroke	a	b	c	d	Force*	Order-number
36	173	82	120	70	0.5 kN	101.110.123.058.036.
50	201	96	120	70	0.5 kN	101.110.123.058.050.
65	231	111	120	70	0.5 kN	101.110.123.058.065.
80	261	126	120	70	0.5 kN	101.110.123.058.080.
100	301	146	120	70	0.5 kN	101.110.123.058.100.
130	361	176	120	70	0.5 kN	101.110.123.058.130.
150	401	196	120	70	0.5 kN	101.110.123.058.150.

\*at 1 bar pressure

**Complete the Order-number:**

Example: 101.110.123.044.050.??? **No. Force connection (S.6)?? No. Cylinder rod (S.7)!**

We reserve the right to make changes which are in the interest of technical progress.

© by WMA Schmidt & Bittner GmbH, Baumwaide 23, D-74360 Illfeld-Auenstein, Tel. +49 7062 9066-0, Fax +49 7062 9066-20

info@wma-sb.de or wma-sb@t-online.de, http://www.wma-sb.de

Cylinder-Ground plate-3



# Welding cylinder

with ground plate

Version: 2011-01

unilateral air connection,  
three-stage pressurized

undamped

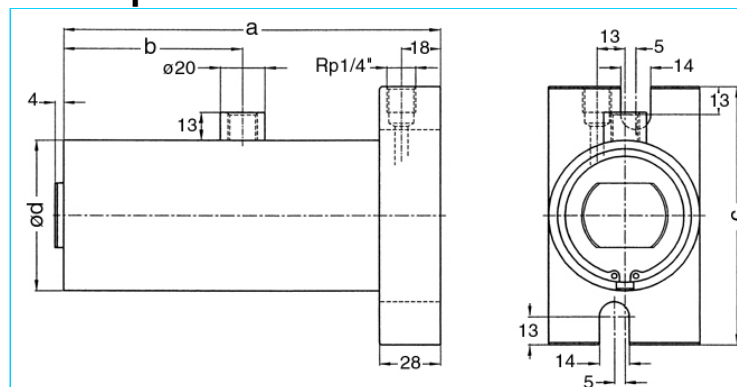

## Nominal size 038

Stroke	a	b	c	d	Force*	Order-number
36	232	141	98	48	0.28 kN	101.110.131.038.036.
50	274	169	98	48	0.28 kN	101.110.131.038.050.
65	319	199	98	48	0.28 kN	101.110.131.038.065.
80	364	229	98	48	0.28 kN	101.110.131.038.080.
100	424	269	98	48	0.28 kN	101.110.131.038.100.
130	514	329	98	48	0.28 kN	101.110.131.038.130.
150	574	369	98	48	0.28 kN	101.110.131.038.150.

\*at 1 bar pressure

## Nominal size 044

Stroke	a	b	c	d	Force*	Order-number
36	232	141	105	55	0.39 kN	101.110.131.044.036.
50	274	169	105	55	0.39 kN	101.110.131.044.050.
65	319	199	105	55	0.39 kN	101.110.131.044.065.
80	364	229	105	55	0.39 kN	101.110.131.044.080.
100	424	269	105	55	0.39 kN	101.110.131.044.100.
130	514	329	105	55	0.39 kN	101.110.131.044.130.
150	574	369	105	55	0.39 kN	101.110.131.044.150.

\*at 1 bar pressure

## Nominal size 058

Stroke	a	b	c	d	Force*	Order-number
36	232	141	120	70	0.72 kN	101.110.131.058.036.
50	274	169	120	70	0.72 kN	101.110.131.058.050.
65	319	199	120	70	0.72 kN	101.110.131.058.065.
80	364	229	120	70	0.72 kN	101.110.131.058.080.
100	424	269	120	70	0.72 kN	101.110.131.058.100.
130	514	329	120	70	0.72 kN	101.110.131.058.130.
150	574	369	120	70	0.72 kN	101.110.131.058.150.

\*at 1 bar pressure

**Complete the Order-number:**

Example: 101.110.131.038.050.??? **No. Force connection (S.6).?? No. Cylinder rod (S.7)!**

We reserve the right to make changes which are in the interest of technical progress.

© by WMA Schmidt & Bittner GmbH, Baumwaide 23, D-74360 Ilsfeld-Auenstein, Tel. +49 7062 9066-0, Fax +49 7062 9066-20

info@wma-sb.de or wma-sb@t-online.de, <http://www.wma-sb.de>

Cylinder-Ground plate-4



# Welding cylinder

with ground plate

Version: 2011-01

unilateral air connection,  
three-stage pressurized

damped independent of stroke

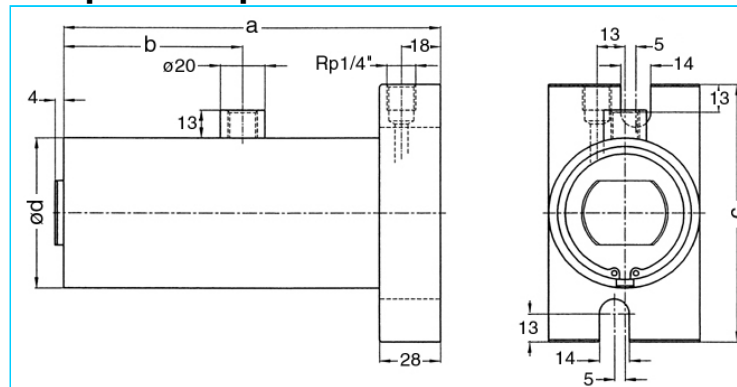

## Nominal size 044

Stroke	a	b	c	d	Force*	Order-number
36	232	141	105	55	0.39 kN	101.110.132.044.036.
50	274	169	105	55	0.39 kN	101.110.132.044.050.
65	319	199	105	55	0.39 kN	101.110.132.044.065.
80	364	229	105	55	0.39 kN	101.110.132.044.080.
100	424	269	105	55	0.39 kN	101.110.132.044.100.
130	514	329	105	55	0.39 kN	101.110.132.044.130.
150	574	369	105	55	0.39 kN	101.110.132.044.150.

\*at 1 bar pressure

## Nominal size 058

Stroke	a	b	c	d	Force*	Order-number
36	232	141	120	70	0.72 kN	101.110.132.058.036.
50	274	169	120	70	0.72 kN	101.110.132.058.050.
65	319	199	120	70	0.72 kN	101.110.132.058.065.
80	364	229	120	70	0.72 kN	101.110.132.058.080.
100	424	269	120	70	0.72 kN	101.110.132.058.100.
130	514	329	120	70	0.72 kN	101.110.132.058.130.
150	574	369	120	70	0.72 kN	101.110.132.058.150.

\*at 1 bar pressure

### Complete the Order-number:

Example: 101.110.132.058.050.??? **No. Force connection (S.6)?? No. Cylinder rod (S.7)!**

We reserve the right to make changes which are in the interest of technical progress.

© by WMA Schmidt & Bittner GmbH, Baumwaide 23, D-74360 Illfeld-Auenstein, Tel. +49 7062 9066-0, Fax +49 7062 9066-20  
info@wma-sb.de or wma-sb@t-online.de, <http://www.wma-sb.de>

Cylinder-Ground plate-5



# Welding cylinder

with ground plate

Version: 2011-01

## Force connection

Write the number (with point) from the selected Force connection direct behind the Order-number of the cylinder and complete the whole Order-number with the chosen number of the Cylinder rod.

**Example:** 101.110.132.058.050.103.?? No. Cylinder rod (S.7)

### Internal cone

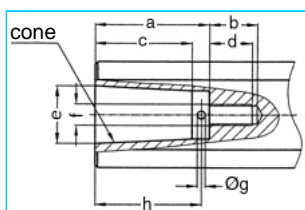

a	b	c	d	e	cone	f	g	h	No.
33	18	27.0	16	17.780	MK2	M8	3	30	101.
42	18	35.5	16	21.806	MK3	M8	3	39	102.
42	18	35.5	16	21.750	1:10	M8	3	39	103.

### Female thread

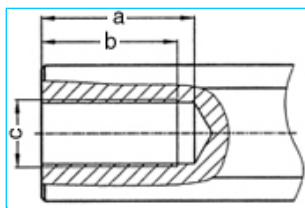

a	b	c	No.
45	40	M20 x 1.5	201.
62	58	M20 x 1.5	202.

### Male thread

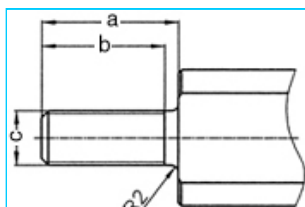

a	b	c	No.
40	36	M16 x 1.5	301.
40	36	M20 x 1.5	302.
40	36	M24 x 1.5	303.

### Knurl

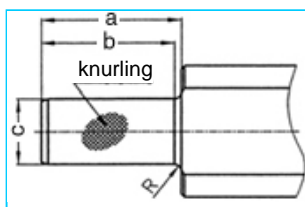

a	b	c	Knurling	R	No.
42	40	20 <sup>17</sup>	1 x 0.2 DIN 82	2	401.
42	42	25 <sup>17</sup>	1 x 0.2 DIN 82	-	402.

We reserve the right to make changes which are in the interest of technical progress.

© by WMA Schmidt & Bittner GmbH, Baumwaide 23, D-74360 Illfeld-Auenstein, Tel. +49 7062 9066-0, Fax +49 7062 9066-20

info@wma-sb.de or wma-sb@t-online.de, <http://www.wma-sb.de>

Cylinder-Ground plate-6



# Welding cylinder

with ground plate

Version: 2011-01

## Cylinder rod

flattened and rotation locked

Complete the Order-number with the selected number of the chosen cylinder rod.

**Example: 101.110.132.058.050.103.03**

### For piston diameter

70, 80, 90

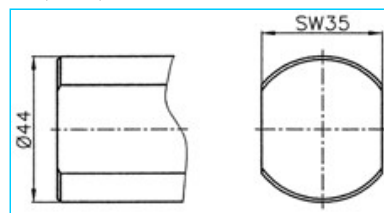

**No. 00**

### For piston diameter

38, 44, 58

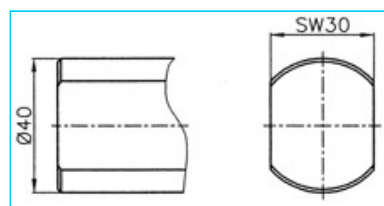

**No. 01**

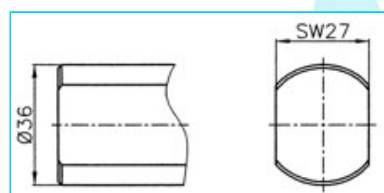

**No. 02**

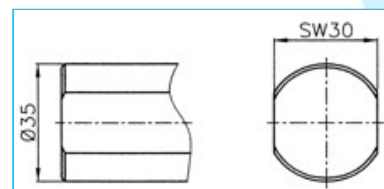

**No. 03**



# Welding cylinder

with ground plate

Version: 2011-01

## Electrode holder for welding cylinders

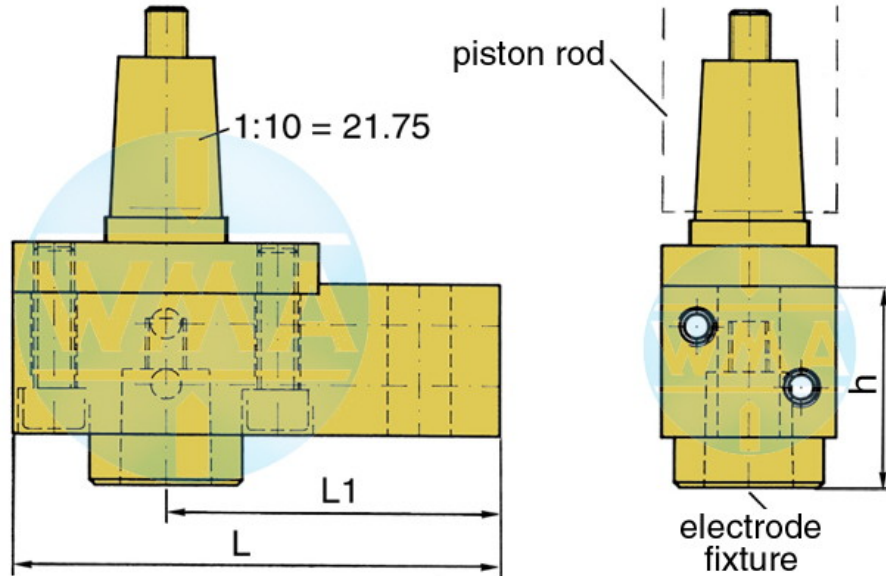

Piston Ø	L	L1	Water connection
38	95	65	possible on both sides
44	95	65	possible on both sides
58	110	80	possible on both sides
70	110	80	possible on both sides
80	120	90	possible on both sides
90	120	90	possible on both sides

## Available cones for the electrode fixture

cone	Ø d	h
1 : 10	9.8	39
1 : 10	12.0	39
1 : 10	12.7	39
1 : 10	15.5	39
1 : 10	15.75	39
1 : 10	17.75	50
1 : 10	19.0	50
MK 1	12.065	39
MK 2	17.781	50

Further cones available on request!



# Welding cylinder

with ground plate

Version: 2011-01

## Electrode holder

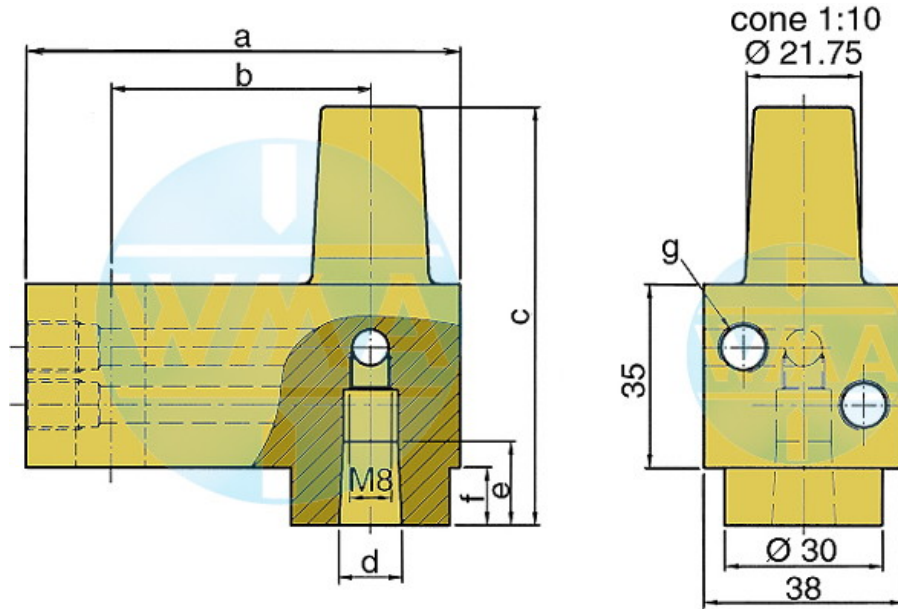

This electrode holder is main used in welding machines with variable and fast-change electrode shafts.

a	b	c	d	e	f	g	Order-number	
82	49	80	1:10=12.00	16	16	11	M10 x 1 or R 1/8"	L60051080-000
82	49	80	MK1	16	16	11	M10 x 1 or R 1/8"	L60091080-000
82	49	80	1:10=15.75	20	20	11	M10 x 1 or R 1/8"	L60131080-001
82	49	80	1:10=18	20	20	11	M10 x 1 or R 1/8"	L60061080-000
82	49	80	MK2	20	20	11	M10 x 1 or R 1/8"	L60101080-000
82	49	90	1:10=21.75	31	31	21	M10 x 1 or R 1/8"	L60221080-000
82	49	90	MK3	31	31	21	M10 x 1 or R 1/8"	L60111080-000
97	64	90	1:10=21.75	31	31	21	M10 x 1 or R 1/8"	L60221090-000
97	64	90	MK3	31	31	21	M10 x 1 or R 1/8"	L60111090-000
107	74	90	1:10=21.75	31	31	21	M10 x 1 or R 1/8"	L60221090-001
107	74	90	MK3	31	31	21	M10 x 1 or R 1/8"	L60111090-001

We reserve the right to make changes which are in the interest of technical progress.

© by WMA Schmidt & Bittner GmbH, Baumwaide 23, D-74360 Iilsfeld-Auenstein, Tel. +49 7062 9066-0, Fax +49 7062 9066-20

info@wma-sb.de or wma-sb@t-online.de, <http://www.wma-sb.de>

Cylinder-Ground plate-9