



# Welding cylinder

with ground plate

Version: 2011-01

**bilateral air connection,  
double-stage pressurized**

**undamped**

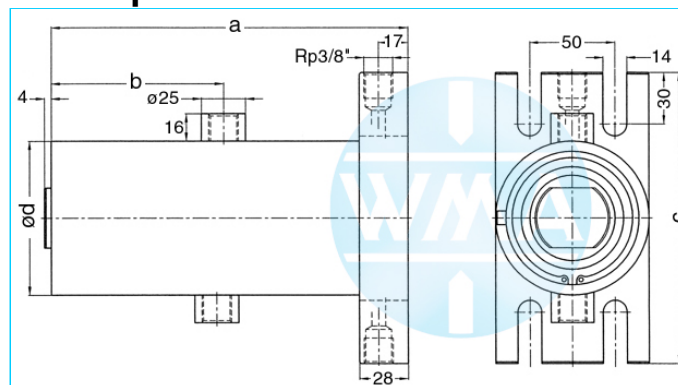

**Nominal size 070  
short model!**

Stroke	a	b	c	d	Force*	Order-number
36	177	95	170	90	0.72 kN	101.113.121.070.036.
50	205	109	170	90	0.72 kN	101.113.121.070.050.
65	235	124	170	90	0.72 kN	101.113.121.070.065.
80	265	139	170	90	0.72 kN	101.113.121.070.080.
100	305	159	170	90	0.72 kN	101.113.121.070.100.
130	365	189	170	90	0.72 kN	101.113.121.070.130.
150	405	209	170	90	0.72 kN	101.113.121.070.150.

\*at 1 bar pressure

**Complete the Order-number: Example: 101.113.121.070.036.???** No. Force connection (S.8).??  
No. Cylinder rod (S.9), write at the end a little k!

**Nominal size 070**

Stroke	a	b	c	d	Force*	Order-number
36	206	99	170	90	0.72 kN	101.113.121.070.036.
50	234	113	170	90	0.72 kN	101.113.121.070.050.
65	264	128	170	90	0.72 kN	101.113.121.070.065.
80	294	143	170	90	0.72 kN	101.113.121.070.080.
100	334	163	170	90	0.72 kN	101.113.121.070.100.
130	394	193	170	90	0.72 kN	101.113.121.070.130.
150	434	213	170	90	0.72 kN	101.113.121.070.150.

\*at 1 bar pressure

**Complete the Order-number:**

Example: **101.113.121.070.036.???** No. Force connection (S.8).?? No. Cylinder rod (S.9)

We reserve the right to make changes which are in the interest of technical progress.

© by WMA Schmidt & Bittner GmbH, Baumwaide 23, D-74360 Illfeld-Auenstein, Tel. +49 7062 9066-0, Fax +49 7062 9066-20

info@wma-sb.de or wma-sb@t-online.de, http://www.wma-sb.de

**Cylinder-Ground plate-1**



# Welding cylinder

with ground plate

Version: 2011-01

**bilateral air connection,  
double-stage pressurized**

**undamped**

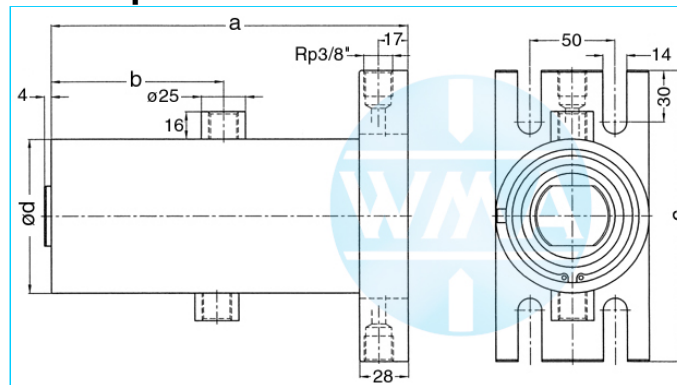

**Nominal size 080  
short model!**

Stroke	a	b	c	d	Force*	Order-number
36	177	95	180	100	0.95 kN	101.113.121.080.036.
50	205	109	180	100	0.95 kN	101.113.121.080.050.
65	235	124	180	100	0.95 kN	101.113.121.080.065.
80	265	139	180	100	0.95 kN	101.113.121.080.080.
100	305	159	180	100	0.95 kN	101.113.121.080.100.
130	365	189	180	100	0.95 kN	101.113.121.080.130.
150	405	209	180	100	0.95 kN	101.113.121.080.150.

\*at 1 bar pressure

**Complete the Order-number: Example: 101.113.121.080.036.???** No. Force connection (S.8).??  
No. Cylinder rod (S.9), write at the end a little k!

**Nominal size 080**

Stroke	a	b	c	d	Force*	Order-number
36	206	99	180	100	0.95 kN	101.113.121.080.036.
50	234	113	180	100	0.95 kN	101.113.121.080.050.
65	264	128	180	100	0.95 kN	101.113.121.080.065.
80	294	143	180	100	0.95 kN	101.113.121.080.080.
100	334	163	180	100	0.95 kN	101.113.121.080.100.
130	394	193	180	100	0.95 kN	101.113.121.080.130.
150	434	213	180	100	0.95 kN	101.113.121.080.150.

\*at 1 bar pressure

**Complete the Order-number:**

Example: **101.113.121.080.036.???** No. Force connection (S.8).?? No. Cylinder rod (S.9)

We reserve the right to make changes which are in the interest of technical progress.

© by WMA Schmidt & Bittner GmbH, Baumwaide 23, D-74360 Illfeld-Auenstein, Tel. +49 7062 9066-0, Fax +49 7062 9066-20

info@wma-sb.de or wma-sb@t-online.de, <http://www.wma-sb.de>

**Cylinder-Ground plate-2**



# Welding cylinder

with ground plate

Version: 2011-01

**bilateral air connection,  
double-stage pressurized**

**undamped**

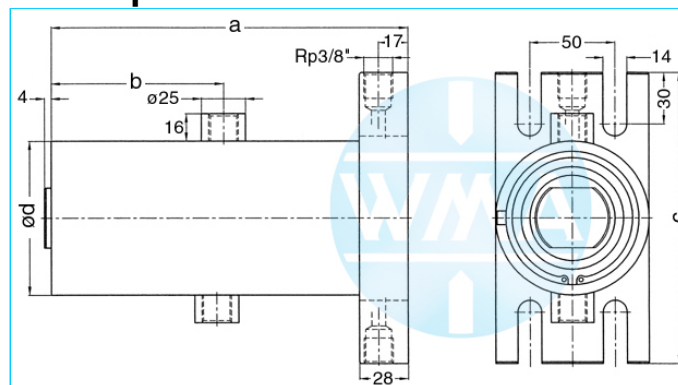

**Nominal size 090  
short model!**

Stroke	a	b	c	d	Force*	Order-number
36	177	95	190	110	1.2 kN	101.113.121.090.036.
50	205	109	190	110	1.2 kN	101.113.121.090.050.
65	235	124	190	110	1.2 kN	101.113.121.090.065.
80	265	139	190	110	1.2 kN	101.113.121.090.080.
100	305	159	190	110	1.2 kN	101.113.121.090.100.
130	365	189	190	110	1.2 kN	101.113.121.090.130.
150	405	209	190	110	1.2 kN	101.113.121.090.150.

\*at 1 bar pressure

**Complete the Order-number: Example: 101.113.121.090.036.???** No. Force connection (S.8).??  
No. Cylinder rod (S.9), write at the end a little k!

**Nominal size 090**

Stroke	a	b	c	d	Force*	Order-number
36	206	99	190	110	1.2 kN	101.113.121.090.036.
50	234	113	190	110	1.2 kN	101.113.121.090.050.
65	264	128	190	110	1.2 kN	101.113.121.090.065.
80	294	143	190	110	1.2 kN	101.113.121.090.080.
100	334	163	190	110	1.2 kN	101.113.121.090.100.
130	394	193	190	110	1.2 kN	101.113.121.090.130.
150	434	213	190	110	1.2 kN	101.113.121.090.150.

\*at 1 bar pressure

**Complete the Order-number:**

Example: **101.113.121.090.036.???** No. Force connection (S.8).?? No. Cylinder rod (S.9)

We reserve the right to make changes which are in the interest of technical progress.

© by WMA Schmidt & Bittner GmbH, Baumwaide 23, D-74360 Illfeld-Auenstein, Tel. +49 7062 9066-0, Fax +49 7062 9066-20

info@wma-sb.de or wma-sb@t-online.de, http://www.wma-sb.de

**Cylinder-Ground plate-3**



# Welding cylinder

with ground plate

Version: 2011-01

**bilateral air connection,  
double-stage pressurized**

**end position damped**

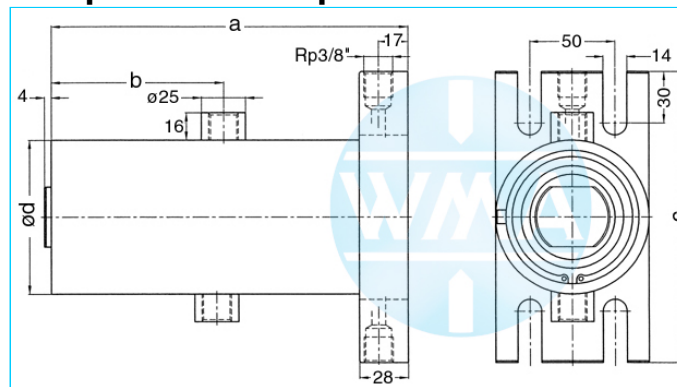

## Nominal size 070

Stroke	a	b	c	d	Force*	Order-number
36	234	113	170	90	0.72 kN	101.113.122.070.036.
50	264	128	170	90	0.72 kN	101.113.122.070.050.
65	294	143	170	90	0.72 kN	101.113.122.070.065.
80	334	163	170	90	0.72 kN	101.113.122.070.080.
100	394	193	170	90	0.72 kN	101.113.122.070.100.
130	434	213	170	90	0.72 kN	101.113.122.070.130.

\*at 1 bar pressure

## Nominal size 080

Stroke	a	b	c	d	Force*	Order-number
36	234	113	180	100	0.95 kN	101.113.122.080.036.
50	264	128	180	100	0.95 kN	101.113.122.080.050.
65	294	143	180	100	0.95 kN	101.113.122.080.065.
80	334	163	180	100	0.95 kN	101.113.122.080.080.
100	394	193	180	100	0.95 kN	101.113.122.080.100.
130	434	213	180	100	0.95 kN	101.113.122.080.130.

\*at 1 bar pressure

## Nominal size 090

Stroke	a	b	c	d	Force*	Order-number
36	234	113	190	110	1.2 kN	101.113.122.090.036.
50	264	128	190	110	1.2 kN	101.113.122.090.050.
65	294	143	190	110	1.2 kN	101.113.122.090.065.
80	334	163	190	110	1.2 kN	101.113.122.090.080.
100	394	193	190	110	1.2 kN	101.113.122.090.100.
130	434	213	190	110	1.2 kN	101.113.122.090.130.

\*at 1 bar pressure

**Complete the Order-number:**

Example: **101.113.122.080.036.???** No. Force connection (S.8).?? No. Cylinder rod (S.9)

We reserve the right to make changes which are in the interest of technical progress.

© by WMA Schmidt & Bittner GmbH, Baumwaide 23, D-74360 Ilfeld-Auenstein, Tel. +49 7062 9066-0, Fax +49 7062 9066-20

info@wma-sb.de or wma-sb@t-online.de, <http://www.wma-sb.de>

**Cylinder-Ground plate-4**



# Welding cylinder

with ground plate

Version: 2011-01

**bilateral air connection,  
double-stage pressurized**

**damped independent of stroke**

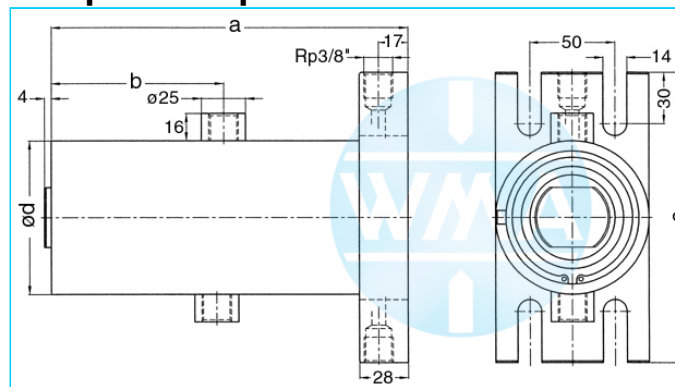

## Nominal size 070

Stroke	a	b	c	d	Force*	Order-number
36	206	99	170	90	0.72 kN	101.113.123.070.036.
50	234	113	170	90	0.72 kN	101.113.123.070.050.
65	264	128	170	90	0.72 kN	101.113.123.070.065.
80	294	143	170	90	0.72 kN	101.113.123.070.080.
100	334	163	170	90	0.72 kN	101.113.123.070.100.
130	394	193	170	90	0.72 kN	101.113.123.070.130.
150	434	213	170	90	0.72 kN	101.113.123.070.150.

\*at 1 bar pressure

## Nominal size 080

Stroke	a	b	c	d	Force*	Order-number
36	206	99	180	100	0.95 kN	101.113.123.080.036.
50	234	113	180	100	0.95 kN	101.113.123.080.050.
65	264	128	180	100	0.95 kN	101.113.123.080.065.
80	294	143	180	100	0.95 kN	101.113.123.080.080.
100	334	163	180	100	0.95 kN	101.113.123.080.100.
130	394	193	180	100	0.95 kN	101.113.123.080.130.
150	434	213	180	100	0.95 kN	101.113.123.080.150.

\*at 1 bar pressure

## Nominal size 090

Stroke	a	b	c	d	Force*	Order-number
36	206	99	190	110	1.2 kN	101.113.123.090.036.
50	234	113	190	110	1.2 kN	101.113.123.090.050.
65	264	128	190	110	1.2 kN	101.113.123.090.065.
80	294	143	190	110	1.2 kN	101.113.123.090.080.
100	334	163	190	110	1.2 kN	101.113.123.090.100.
130	394	193	190	110	1.2 kN	101.113.123.090.130.
150	434	213	190	110	1.2 kN	101.113.123.090.150.

\*at 1 bar pressure

### Complete the Order-number:

Example: **101.113.123.080.036.???** No. Force connection (S.8).?? No. Cylinder rod (S.9)

We reserve the right to make changes which are in the interest of technical progress.

© by WMA Schmidt & Bittner GmbH, Baumwaide 23, D-74360 Illfeld-Auenstein, Tel. +49 7062 9066-0, Fax +49 7062 9066-20

info@wma-sb.de or wma-sb@t-online.de, <http://www.wma-sb.de>

**Cylinder-Ground plate-5**



# Welding cylinder

with ground plate

Version: 2011-01

**bilateral air connection,  
three-stage pressurized**

**undamped**

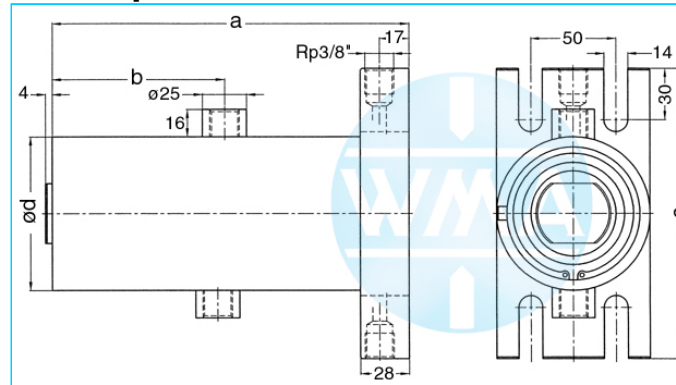

## Nominal size 070

Stroke	a	b	c	d	Force*	Order-number
36	276	169	170	90	1.04 kN	101.113.131.070.036.
50	318	197	170	90	1.04 kN	101.113.131.070.050.
65	363	227	170	90	1.04 kN	101.113.131.070.065.
80	408	257	170	90	1.04 kN	101.113.131.070.080.
100	468	297	170	90	1.04 kN	101.113.131.070.100.
130	558	357	170	90	1.04 kN	101.113.131.070.130.
150	618	397	170	90	1.04 kN	101.113.131.070.150.

\*at 1 bar pressure

## Nominal size 080

Stroke	a	b	c	d	Force*	Order-number
36	276	169	180	100	1.4 kN	101.113.131.080.036.
50	318	197	180	100	1.4 kN	101.113.131.080.050.
65	363	227	180	100	1.4 kN	101.113.131.080.065.
80	408	257	180	100	1.4 kN	101.113.131.080.080.
100	468	297	180	100	1.4 kN	101.113.131.080.100.
130	558	357	180	100	1.4 kN	101.113.131.080.130.
150	618	397	180	100	1.4 kN	101.113.131.080.150.

\*at 1 bar pressure

## Nominal size 090

Stroke	a	b	c	d	Force*	Order-number
36	276	169	190	110	1.8 kN	101.113.131.090.036.
50	318	197	190	110	1.8 kN	101.113.131.090.050.
65	363	227	190	110	1.8 kN	101.113.131.090.065.
80	408	257	190	110	1.8 kN	101.113.131.090.080.
100	468	297	190	110	1.8 kN	101.113.131.090.100.
130	558	357	190	110	1.8 kN	101.113.131.090.130.
150	618	397	190	110	1.8 kN	101.113.131.090.150.

\*at 1 bar pressure

**Complete the Order-number:**

Example: **101.113.131.080.036.???** No. Force connection (S.8).?? No. Cylinder rod (S.9)

We reserve the right to make changes which are in the interest of technical progress.

© by WMA Schmidt & Bittner GmbH, Baumwaide 23, D-74360 Illfeld-Auenstein, Tel. +49 7062 9066-0, Fax +49 7062 9066-20

info@wma-sb.de or wma-sb@t-online.de, <http://www.wma-sb.de>

**Cylinder-Ground plate-6**



# Welding cylinder

with ground plate

Version: 2011-01

**bilateral air connection,  
three-stage pressurized**

**damped independent of stroke**

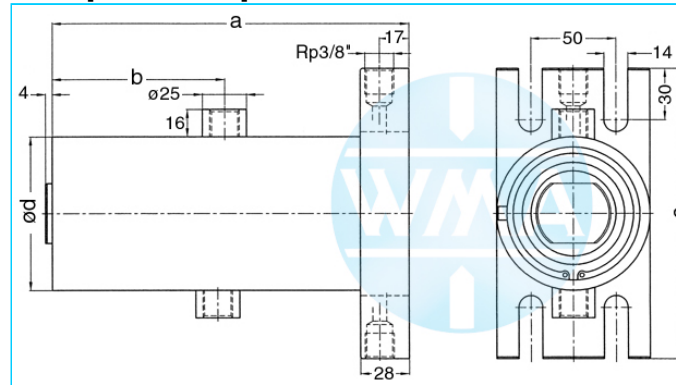

## Nominal size 070

Stroke	a	b	c	d	Force*	Order-number
36	276	169	170	90	1.04 kN	101.113.132.070.036.
50	318	197	170	90	1.04 kN	101.113.132.070.050.
65	363	227	170	90	1.04 kN	101.113.132.070.065.
80	408	257	170	90	1.04 kN	101.113.132.070.080.
100	468	297	170	90	1.04 kN	101.113.132.070.100.
130	558	357	170	90	1.04 kN	101.113.132.070.130.
150	618	397	170	90	1.04 kN	101.113.132.070.150.

\*at 1 bar pressure

## Nominal size 080

Stroke	a	b	c	d	Force*	Order-number
36	276	169	180	100	1.4 kN	101.113.132.080.036.
50	318	197	180	100	1.4 kN	101.113.132.080.050.
65	363	227	180	100	1.4 kN	101.113.132.080.065.
80	408	257	180	100	1.4 kN	101.113.132.080.080.
100	468	297	180	100	1.4 kN	101.113.132.080.100.
130	558	357	180	100	1.4 kN	101.113.132.080.130.
150	618	397	180	100	1.4 kN	101.113.132.080.150.

\*at 1 bar pressure

## Nominal size 090

Stroke	a	b	c	d	Force*	Order-number
36	276	169	190	110	1.8 kN	101.113.132.090.036.
50	318	197	190	110	1.8 kN	101.113.132.090.050.
65	363	227	190	110	1.8 kN	101.113.132.090.065.
80	408	257	190	110	1.8 kN	101.113.132.090.080.
100	468	297	190	110	1.8 kN	101.113.132.090.100.
130	558	357	190	110	1.8 kN	101.113.132.090.130.
150	618	397	190	110	1.8 kN	101.113.132.090.150.

\*at 1 bar pressure

### Complete the Order-number:

Example: **101.113.132.080.036.???** No. Force connection (S.8).?? No. Cylinder rod (S.9)

We reserve the right to make changes which are in the interest of technical progress.

© by WMA Schmidt & Bittner GmbH, Baumwaide 23, D-74360 Illfeld-Auenstein, Tel. +49 7062 9066-0, Fax +49 7062 9066-20

info@wma-sb.de or wma-sb@t-online.de, <http://www.wma-sb.de>

**Cylinder-Ground plate-7**



# Welding cylinder

with ground plate

Version: 2011-01

## Force connection

Write the number (with point) from the selected Force connection direct behind the Order-number of the cylinder and complete the whole Order-number with the chosen number of the Cylinder rod.

**Example:** 101.113.121.070.036.103.?? No. Cylinder rod (S.9)

### Internal cone

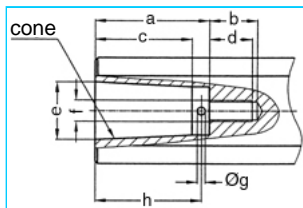

a	b	c	d	e	cone	f	g	h	No.
33	18	27.0	16	17.780	MK2	M8	3	30	101.
42	18	35.5	16	21.806	MK3	M8	3	39	102.
42	18	35.5	16	21.750	1:10	M8	3	39	103.

### Female thread

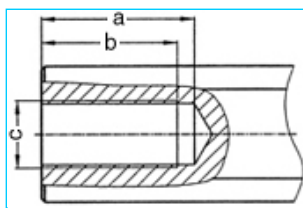

a	b	c	No.
45	40	M20 x 1.5	201.
62	58	M20 x 1.5	202.

### Male thread

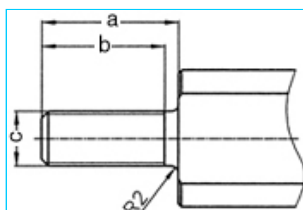

a	b	c	No.
40	36	M16 x 1.5	301.
40	36	M20 x 1.5	302.
40	36	M24 x 1.5	303.

### Knurl

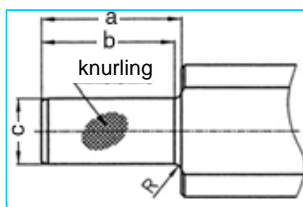

a	b	c	Knurling	R	No.
42	40	2017	1 x 0.2 DIN 82	2	401.
42	42	2517	1 x 0.2 DIN 82	-	402.

We reserve the right to make changes which are in the interest of technical progress.

© by WMA Schmidt & Bittner GmbH, Baumwaide 23, D-74360 Illfeld-Auenstein, Tel. +49 7062 9066-0, Fax +49 7062 9066-20

info@wma-sb.de or wma-sb@t-online.de, <http://www.wma-sb.de>

**Cylinder-Ground plate-8**



# Welding cylinder

with ground plate

Version: 2011-01

## Cylinder rod

flattened and rotation locked

Complete the Order-number with the selected number of the chosen cylinder rod.

**Example: 101.113.121.070.036.103.00**

### For piston diameter

70, 80, 90

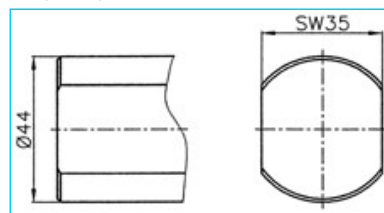

**No. 00**

### For piston diameter

38, 44, 58

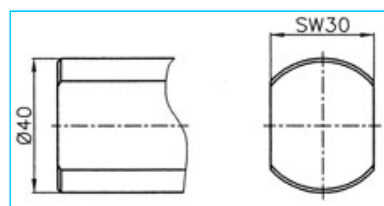

**No. 01**

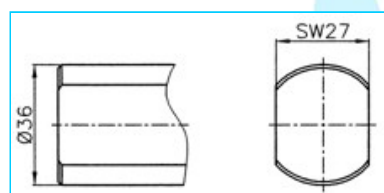

**No. 02**

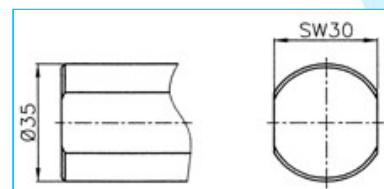

**No. 03**



# Welding cylinder

with ground plate

Version: 2011-01

## Electrode holder for welding cylinders

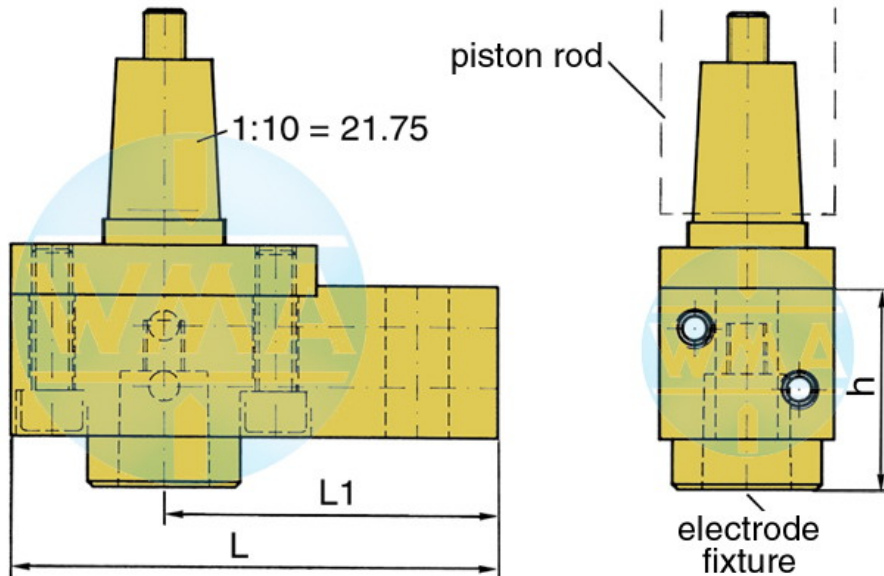

Piston Ø	L	L1	Water connection
38	95	65	possible on both sides
44	95	65	possible on both sides
58	110	80	possible on both sides
70	110	80	possible on both sides
80	120	90	possible on both sides
90	120	90	possible on both sides

## Available cones for the electrode fixture

cone	Ø d	h
1 : 10	9.8	39
1 : 10	12.0	39
1 : 10	12.7	39
1 : 10	15.5	39
1 : 10	15.75	39
1 : 10	17.75	50
1 : 10	19.0	50
MK 1	12.065	39
MK 2	17.781	50

Further cones available on request!



# Welding cylinder

with ground plate

Version: 2011-01

## Electrode holder

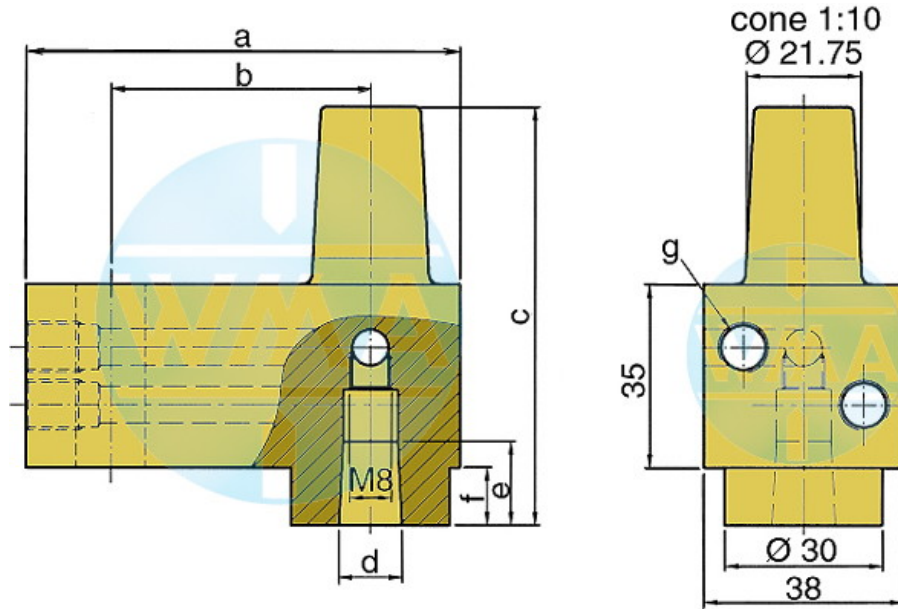

This electrode holder is main used in welding machines with variable and fast-change electrode shafts.

a	b	c	d	e	f	g	Order-number	
82	49	80	1:10=12.00	16	16	11	M10 x 1 or R 1/8"	L60051080-000
82	49	80	MK1	16	16	11	M10 x 1 or R 1/8"	L60091080-000
82	49	80	1:10=15.75	20	20	11	M10 x 1 or R 1/8"	L60131080-001
82	49	80	1:10=18	20	20	11	M10 x 1 or R 1/8"	L60061080-000
82	49	80	MK2	20	20	11	M10 x 1 or R 1/8"	L60101080-000
82	49	90	1:10=21.75	31	31	21	M10 x 1 or R 1/8"	L60221080-000
82	49	90	MK3	31	31	21	M10 x 1 or R 1/8"	L60111080-000
97	64	90	1:10=21.75	31	31	21	M10 x 1 or R 1/8"	L60221090-000
97	64	90	MK3	31	31	21	M10 x 1 or R 1/8"	L60111090-000
107	74	90	1:10=21.75	31	31	21	M10 x 1 or R 1/8"	L60221090-001
107	74	90	MK3	31	31	21	M10 x 1 or R 1/8"	L60111090-001

We reserve the right to make changes which are in the interest of technical progress.

© by WMA Schmidt & Bittner GmbH, Baumwaide 23, D-74360 Illfeld-Auenstein, Tel. +49 7062 9066-0, Fax +49 7062 9066-20

info@wma-sb.de or wma-sb@t-online.de, <http://www.wma-sb.de>

**Cylinder-Ground plate-11**