



Welding cylinder

Bottom flange

Version: 2011-01

unilateral air connection,
double-stage pressurized

undamped

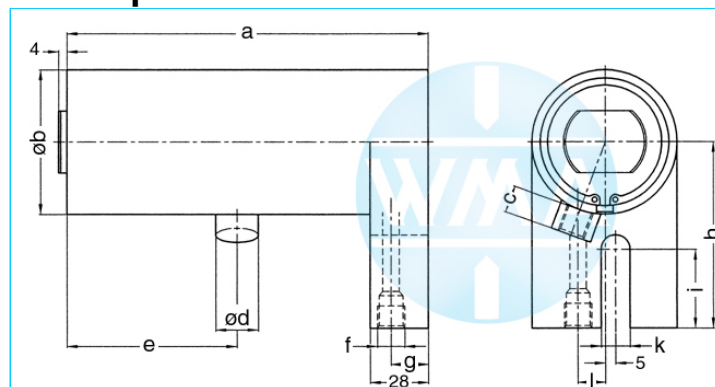

Nominal size 038

S	a	b	c	d	e	f	g	h	i	k	l	Force*	Order-number
36	173	48	13	20	82	Rp1/4"	18	75	38	14	13	0.2 kN	103.110.121.038.036.
50	201	48	13	20	96	Rp1/4"	18	75	38	14	13	0.2 kN	103.110.121.038.050.
65	231	48	13	20	111	Rp1/4"	18	75	38	14	13	0.2 kN	103.110.121.038.065.
80	261	48	13	20	126	Rp1/4"	18	75	38	14	13	0.2 kN	103.110.121.038.080.
100	301	48	13	20	146	Rp1/4"	18	75	38	14	13	0.2 kN	103.110.121.038.100.
130	361	48	13	20	176	Rp1/4"	18	75	38	14	13	0.2 kN	103.110.121.038.130.
150	401	48	13	20	196	Rp1/4"	18	75	38	14	13	0.2 kN	103.110.121.038.150.

S = stroke, * at 1 bar pressure

Nominal size 044

S	a	b	c	d	e	f	g	h	i	k	l	Force*	Order-number
36	173	55	13	20	82	Rp1/4"	18	80	38	14	13	0.28 kN	103.110.121.044.036.
50	201	55	13	20	96	Rp1/4"	18	80	38	14	13	0.28 kN	103.110.121.044.050.
65	231	55	13	20	111	Rp1/4"	18	80	38	14	13	0.28 kN	103.110.121.044.065.
80	261	55	13	20	126	Rp1/4"	18	80	38	14	13	0.28 kN	103.110.121.044.080.
100	301	55	13	20	146	Rp1/4"	18	80	38	14	13	0.28 kN	103.110.121.044.100.
130	361	55	13	20	176	Rp1/4"	18	80	38	14	13	0.28 kN	103.110.121.044.130.
150	401	55	13	20	196	Rp1/4"	18	80	38	14	13	0.28 kN	103.110.121.044.150.

S = stroke, * at 1 bar pressure

Nominal size 058

S	a	b	c	d	e	f	g	h	i	k	l	Force*	Order-number
36	173	70	13	20	82	Rp1/4"	18	90	38	14	13	0.5 kN	103.110.121.058.036.
50	201	70	13	20	96	Rp1/4"	18	90	38	14	13	0.5 kN	103.110.121.058.050.
65	231	70	13	20	111	Rp1/4"	18	90	38	14	13	0.5 kN	103.110.121.058.065.
80	261	70	13	20	126	Rp1/4"	18	90	38	14	13	0.5 kN	103.110.121.058.080.
100	301	70	13	20	146	Rp1/4"	18	90	38	14	13	0.5 kN	103.110.121.058.100.
130	361	70	13	20	176	Rp1/4"	18	90	38	14	13	0.5 kN	103.110.121.058.130.
150	401	70	13	20	196	Rp1/4"	18	90	38	14	13	0.5 kN	103.110.121.058.150.

S = stroke, * at 1 bar pressure

Complete the Order-number:

Example: 103.110.121.058.036.??? No. Force connection (S.10).?? No. Cylinder rod (S.11)!

We reserve the right to make changes which are in the interest of technical progress.

© by WMA Schmidt & Bittner GmbH, Baumwaide 23, D-74360 Illfeld-Auenstein, Tel. +49 7062 9066-0, Fax +49 7062 9066-20

info@wma-sb.de or wma-sb@t-online.de, <http://www.wma-sb.de>

Cylinder-Bottom flange-1



Welding cylinder

Bottom flange

Version: 2011-01

unilateral air connection,
double-stage pressurized

undamped

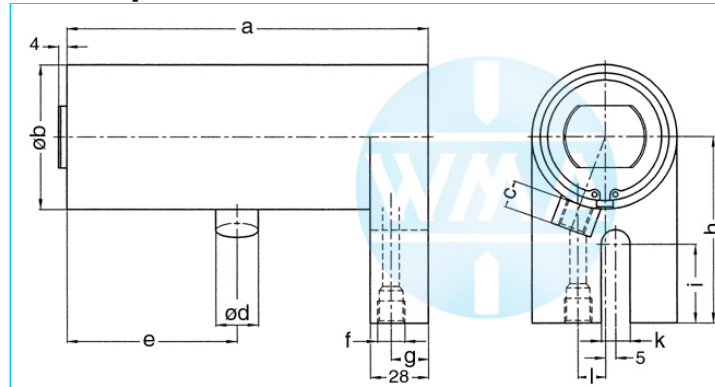

Nominal size 070

S	a	b	c	d	e	f	g	h	i	k	l	Force*	Order-number
36	206	90	16	25	99	Rp3/8"	17	110	49	17	16	0.72 kN	103.110.121.070.036.
50	234	90	16	25	113	Rp3/8"	17	110	49	17	16	0.72 kN	103.110.121.070.050.
65	264	90	16	25	128	Rp3/8"	17	110	49	17	16	0.72 kN	103.110.121.070.065.
80	294	90	16	25	143	Rp3/8"	17	110	49	17	16	0.72 kN	103.110.121.070.080.
100	334	90	16	25	163	Rp3/8"	17	110	49	17	16	0.72 kN	103.110.121.070.100.
130	394	90	16	25	193	Rp3/8"	17	110	49	17	16	0.72 kN	103.110.121.070.130.
150	434	90	16	25	213	Rp3/8"	17	110	49	17	16	0.72 kN	103.110.121.070.150.

S = stroke, * at 1 bar pressure

Nominal size 080

S	a	b	c	d	e	f	g	h	i	k	l	Force*	Order-number
36	206	100	16	25	99	Rp3/8"	17	120	49	17	16	0.95 kN	103.110.121.080.036.
50	234	100	16	25	113	Rp3/8"	17	120	49	17	16	0.95 kN	103.110.121.080.050.
65	264	100	16	25	128	Rp3/8"	17	120	49	17	16	0.95 kN	103.110.121.080.065.
80	294	100	16	25	143	Rp3/8"	17	120	49	17	16	0.95 kN	103.110.121.080.080.
100	334	100	16	25	163	Rp3/8"	17	120	49	17	16	0.95 kN	103.110.121.080.100.
130	394	100	16	25	193	Rp3/8"	17	120	49	17	16	0.95 kN	103.110.121.080.130.
150	434	100	16	25	213	Rp3/8"	17	120	49	17	16	0.95 kN	103.110.121.080.150.

S = stroke, * at 1 bar pressure

Nominal size 090

S	a	b	c	d	e	f	g	h	i	k	l	Force*	Order-number
36	206	110	16	25	99	Rp3/8"	17	130	49	17	16	1.2 kN	103.110.121.090.036.
50	234	110	16	25	113	Rp3/8"	17	130	49	17	16	1.2 kN	103.110.121.090.050.
65	264	110	16	25	128	Rp3/8"	17	130	49	17	16	1.2 kN	103.110.121.090.065.
80	294	110	16	25	143	Rp3/8"	17	130	49	17	16	1.2 kN	103.110.121.090.080.
100	334	110	16	25	163	Rp3/8"	17	130	49	17	16	1.2 kN	103.110.121.090.100.
130	394	110	16	25	193	Rp3/8"	17	130	49	17	16	1.2 kN	103.110.121.090.130.
150	434	110	16	25	213	Rp3/8"	17	130	49	17	16	1.2 kN	103.110.121.090.150.

S = stroke, * at 1 bar pressure

Complete the Order-number:

Example: 103.110.121.080.036.??? No. Force connection (S.10).?? No. Cylinder rod (S.11)!

We reserve the right to make changes which are in the interest of technical progress.

© by WMA Schmidt & Bittner GmbH, Baumwaide 23, D-74360 Illfeld-Auenstein, Tel. +49 7062 9066-0, Fax +49 7062 9066-20

info@wma-sb.de or wma-sb@t-online.de, http://www.wma-sb.de

Cylinder-Bottom flange-2



Welding cylinder

Bottom flange

Version: 2011-01

unilateral air connection,
double-stage pressurized

end position damped

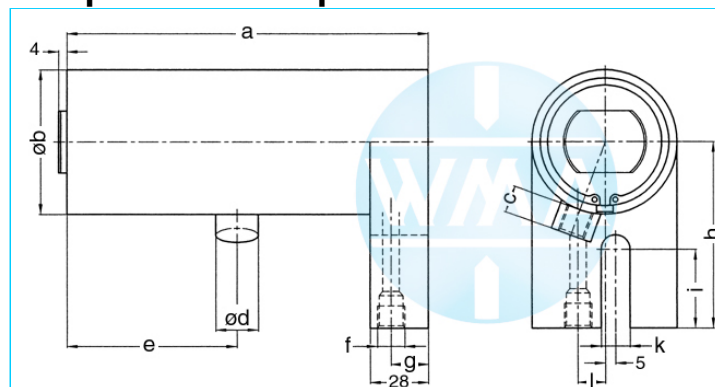

Nominal size 044

S	a	b	c	d	e	f	g	h	i	k	l	Force*	Order-number
36	201	55	13	20	96	Rp1/4"	18	80	38	14	13	0.28 kN	103.110.122.044.036.
50	231	55	13	20	111	Rp1/4"	18	80	38	14	13	0.28 kN	103.110.122.044.050.
65	261	55	13	20	126	Rp1/4"	18	80	38	14	13	0.28 kN	103.110.122.044.065.
80	301	55	13	20	146	Rp1/4"	18	80	38	14	13	0.28 kN	103.110.122.044.080.
100	361	55	13	20	176	Rp1/4"	18	80	38	14	13	0.28 kN	103.110.122.044.100.
130	401	55	13	20	196	Rp1/4"	18	80	38	14	13	0.28 kN	103.110.122.044.130.

S = stroke, * at 1 bar pressure

Nominal size 058

S	a	b	c	d	e	f	g	h	i	k	l	Force*	Order-number
36	201	70	13	20	96	Rp1/4"	18	90	38	14	13	0.5 kN	103.110.122.058.036.
50	231	70	13	20	111	Rp1/4"	18	90	38	14	13	0.5 kN	103.110.122.058.050.
65	261	70	13	20	126	Rp1/4"	18	90	38	14	13	0.5 kN	103.110.122.058.065.
80	301	70	13	20	146	Rp1/4"	18	90	38	14	13	0.5 kN	103.110.122.058.080.
100	361	70	13	20	176	Rp1/4"	18	90	38	14	13	0.5 kN	103.110.122.058.100.
130	401	70	13	20	196	Rp1/4"	18	90	38	14	13	0.5 kN	103.110.122.058.130.

S = stroke, * at 1 bar pressure

Complete the Order-number:

Example: 103.110.122.058.065.??? No. Force connection (S.10).?? No. Cylinder rod (S.11)!

We reserve the right to make changes which are in the interest of technical progress.

© by WMA Schmidt & Bittner GmbH, Baumwaide 23, D-74360 Illfeld-Auenstein, Tel. +49 7062 9066-0, Fax +49 7062 9066-20

info@wma-sb.de or wma-sb@t-online.de, <http://www.wma-sb.de>

Cylinder-Bottom flange-3



Welding cylinder

Bottom flange

Version: 2011-01

unilateral air connection,
double-stage pressurized

end position damped

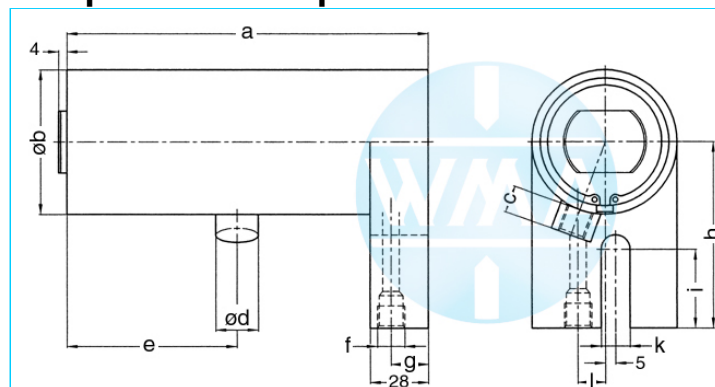

Nominal size 070

S	a	b	c	d	e	f	g	h	i	k	l	Force*	Order-number
36	234	90	16	25	113	Rp3/8"	17	110	49	17	16	0.72 kN	103.110.122.070.036.
50	264	90	16	25	128	Rp3/8"	17	110	49	17	16	0.72 kN	103.110.122.070.050.
65	294	90	16	25	143	Rp3/8"	17	110	49	17	16	0.72 kN	103.110.122.070.065.
80	334	90	16	25	163	Rp3/8"	17	110	49	17	16	0.72 kN	103.110.122.070.080.
100	394	90	16	25	193	Rp3/8"	17	110	49	17	16	0.72 kN	103.110.122.070.100.
130	434	90	16	25	213	Rp3/8"	17	110	49	17	16	0.72 kN	103.110.122.070.130.

S = stroke, * at 1 bar pressure

Nominal size 080

S	a	b	c	d	e	f	g	h	i	k	l	Force*	Order-number
36	234	100	16	25	113	Rp3/8"	17	120	49	17	16	0.95 kN	103.110.122.080.036.
50	264	100	16	25	128	Rp3/8"	17	120	49	17	16	0.95 kN	103.110.122.080.050.
65	294	100	16	25	143	Rp3/8"	17	120	49	17	16	0.95 kN	103.110.122.080.065.
80	334	100	16	25	163	Rp3/8"	17	120	49	17	16	0.95 kN	103.110.122.080.080.
100	394	100	16	25	193	Rp3/8"	17	120	49	17	16	0.95 kN	103.110.122.080.100.
130	434	100	16	25	213	Rp3/8"	17	120	49	17	16	0.95 kN	103.110.122.080.130.

S = stroke, * at 1 bar pressure

Nominal size 090

S	a	b	c	d	e	f	g	h	i	k	l	Force*	Order-number
36	234	110	16	25	113	Rp3/8"	17	130	49	17	16	1.2 kN	103.110.122.090.036.
50	264	110	16	25	128	Rp3/8"	17	130	49	17	16	1.2 kN	103.110.122.090.050.
65	294	110	16	25	143	Rp3/8"	17	130	49	17	16	1.2 kN	103.110.122.090.065.
80	334	110	16	25	163	Rp3/8"	17	130	49	17	16	1.2 kN	103.110.122.090.080.
100	394	110	16	25	193	Rp3/8"	17	130	49	17	16	1.2 kN	103.110.122.090.100.
130	434	110	16	25	213	Rp3/8"	17	130	49	17	16	1.2 kN	103.110.122.090.130.

S = stroke, * at 1 bar pressure

Complete the Order-number:

Example: 103.110.122.090.036.??? No. Force connection (S.10).?? No. Cylinder rod (S.11)!

We reserve the right to make changes which are in the interest of technical progress.

© by WMA Schmidt & Bittner GmbH, Baumwaide 23, D-74360 Illfeld-Auenstein, Tel. +49 7062 9066-0, Fax +49 7062 9066-20

info@wma-sb.de or wma-sb@t-online.de, <http://www.wma-sb.de>

Cylinder-Bottom flange-4



Welding cylinder

Bottom flange

Version: 2011-01

unilateral air connection,
double-stage pressurized

damped independent of stroke

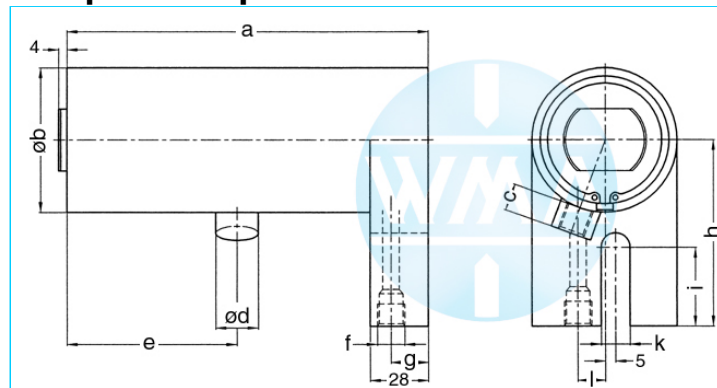

Nominal size 044

S	a	b	c	d	e	f	g	h	i	k	l	Force*	Order-number
36	173	55	13	20	82	Rp1/4"	18	80	38	14	13	0.28 kN	103.110.123.044.036.
50	201	55	13	20	96	Rp1/4"	18	80	38	14	13	0.28 kN	103.110.123.044.050.
65	231	55	13	20	111	Rp1/4"	18	80	38	14	13	0.28 kN	103.110.123.044.065.
80	261	55	13	20	126	Rp1/4"	18	80	38	14	13	0.28 kN	103.110.123.044.080.
100	301	55	13	20	146	Rp1/4"	18	80	38	14	13	0.28 kN	103.110.123.044.100.
130	361	55	13	20	176	Rp1/4"	18	80	38	14	13	0.28 kN	103.110.123.044.130.
150	401	55	13	20	196	Rp1/4"	18	80	38	14	13	0.28 kN	103.110.123.044.150.

S = stroke, * at 1 bar pressure

Nominal size 058

S	a	b	c	d	e	f	g	h	i	k	l	Force*	Order-number
36	173	70	13	20	82	Rp1/4"	18	90	38	14	13	0.5 kN	103.110.123.058.036.
50	201	70	13	20	96	Rp1/4"	18	90	38	14	13	0.5 kN	103.110.123.058.050.
65	231	70	13	20	111	Rp1/4"	18	90	38	14	13	0.5 kN	103.110.123.058.065.
80	261	70	13	20	126	Rp1/4"	18	90	38	14	13	0.5 kN	103.110.123.058.080.
100	301	70	13	20	146	Rp1/4"	18	90	38	14	13	0.5 kN	103.110.123.058.100.
130	361	70	13	20	176	Rp1/4"	18	90	38	14	13	0.5 kN	103.110.123.058.130.
150	401	70	13	20	196	Rp1/4"	18	90	38	14	13	0.5 kN	103.110.123.058.150.

S = stroke, * at 1 bar pressure

Nominal size 070

S	a	b	c	d	e	f	g	h	i	k	l	Force*	Order-number
36	206	90	16	25	99	Rp3/8"	17	110	49	17	16	0.72 kN	103.110.123.070.036.
50	234	90	16	25	113	Rp3/8"	17	110	49	17	16	0.72 kN	103.110.123.070.050.
65	264	90	16	25	128	Rp3/8"	17	110	49	17	16	0.72 kN	103.110.123.070.065.
80	294	90	16	25	143	Rp3/8"	17	110	49	17	16	0.72 kN	103.110.123.070.080.
100	334	90	16	25	163	Rp3/8"	17	110	49	17	16	0.72 kN	103.110.123.070.100.
130	394	90	16	25	193	Rp3/8"	17	110	49	17	16	0.72 kN	103.110.123.070.130.
150	434	90	16	25	213	Rp3/8"	17	110	49	17	16	0.72 kN	103.110.123.070.150.

S = stroke, * at 1 bar pressure

Complete the Order-number:

Example: 103.110.123.058.036.??? No. Force connection (S.10).?? No. Cylinder rod (S.11)!

We reserve the right to make changes which are in the interest of technical progress.

© by WMA Schmidt & Bittner GmbH, Baumwaide 23, D-74360 Illfeld-Auenstein, Tel. +49 7062 9066-0, Fax +49 7062 9066-20

info@wma-sb.de or wma-sb@t-online.de, http://www.wma-sb.de

Cylinder-Bottom flange-5



Welding cylinder

Bottom flange

Version: 2011-01

unilateral air connection,
double-stage pressurized

damped independent of stroke

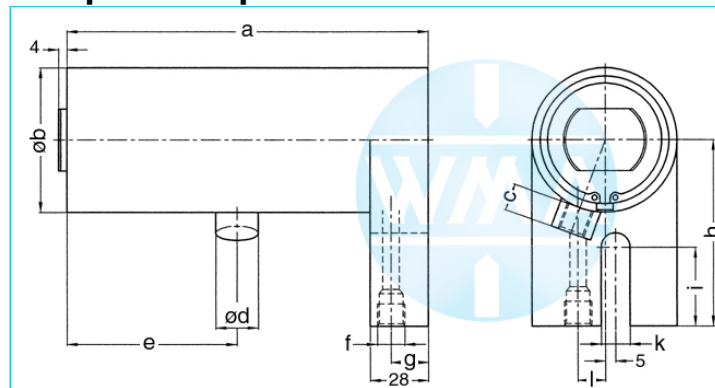

Nominal size 080

S	a	b	c	d	e	f	g	h	i	k	l	Force*	Order-number
36	206	100	16	25	99	Rp3/8"	17	120	49	17	16	0.95 kN	103.110.123.080.036.
50	234	100	16	25	113	Rp3/8"	17	120	49	17	16	0.95 kN	103.110.123.080.050.
65	264	100	16	25	128	Rp3/8"	17	120	49	17	16	0.95 kN	103.110.123.080.065.
80	294	100	16	25	143	Rp3/8"	17	120	49	17	16	0.95 kN	103.110.123.080.080.
100	334	100	16	25	163	Rp3/8"	17	120	49	17	16	0.95 kN	103.110.123.080.100.
130	394	100	16	25	193	Rp3/8"	17	120	49	17	16	0.95 kN	103.110.123.080.130.
150	434	100	16	25	213	Rp3/8"	17	120	49	17	16	0.95 kN	103.110.123.080.150.

S = stroke, * at 1 bar pressure

Nominal size 090

S	a	b	c	d	e	f	g	h	i	k	l	Force*	Order-number
36	206	110	16	25	99	Rp3/8"	17	130	49	17	16	1.2 kN	103.110.123.090.036.
50	234	110	16	25	113	Rp3/8"	17	130	49	17	16	1.2 kN	103.110.123.090.050.
65	264	110	16	25	128	Rp3/8"	17	130	49	17	16	1.2 kN	103.110.123.090.065.
80	294	110	16	25	143	Rp3/8"	17	130	49	17	16	1.2 kN	103.110.123.090.080.
100	334	110	16	25	163	Rp3/8"	17	130	49	17	16	1.2 kN	103.110.123.090.100.
130	394	110	16	25	193	Rp3/8"	17	130	49	17	16	1.2 kN	103.110.123.090.130.
150	434	110	16	25	213	Rp3/8"	17	130	49	17	16	1.2 kN	103.110.123.090.150.

S = stroke, * at 1 bar pressure

Complete the Order-number:

Example: 103.110.123.090.036.??? No. Force connection (S.10).?? No. Cylinder rod (S.11)!

We reserve the right to make changes which are in the interest of technical progress.

© by WMA Schmidt & Bittner GmbH, Baumwaide 23, D-74360 Illfeld-Auenstein, Tel. +49 7062 9066-0, Fax +49 7062 9066-20

info@wma-sb.de or wma-sb@t-online.de, <http://www.wma-sb.de>

Cylinder-Bottom flange-6



Welding cylinder

Bottom flange

Version: 2011-01

unilateral air connection,
three-stage pressurized

undamped

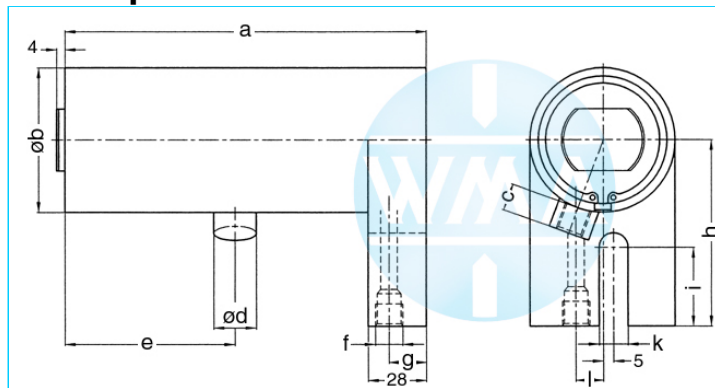

Nominal size 038

S	a	b	c	d	e	f	g	h	i	k	l	Force*	Order-number
36	232	48	13	20	141	Rp1/4"	18	75	38	14	13	0.28 kN	103.110.131.038.036.
50	274	48	13	20	169	Rp1/4"	18	75	38	14	13	0.28 kN	103.110.131.038.050.
65	319	48	13	20	199	Rp1/4"	18	75	38	14	13	0.28 kN	103.110.131.038.065.
80	364	48	13	20	229	Rp1/4"	18	75	38	14	13	0.28 kN	103.110.131.038.080.
100	424	48	13	20	269	Rp1/4"	18	75	38	14	13	0.28 kN	103.110.131.038.100.
130	514	48	13	20	329	Rp1/4"	18	75	38	14	13	0.28 kN	103.110.131.038.130.
150	574	48	13	20	369	Rp1/4"	18	75	38	14	13	0.28 kN	103.110.131.038.150.

S = stroke, * at 1 bar pressure

Nominal size 044

S	a	b	c	d	e	f	g	h	i	k	l	Force*	Order-number
36	232	55	13	20	141	Rp1/4"	18	80	38	14	13	0.39 kN	103.110.131.044.036.
50	274	55	13	20	169	Rp1/4"	18	80	38	14	13	0.39 kN	103.110.131.044.050.
65	319	55	13	20	199	Rp1/4"	18	80	38	14	13	0.39 kN	103.110.131.044.065.
80	364	55	13	20	229	Rp1/4"	18	80	38	14	13	0.39 kN	103.110.131.044.080.
100	424	55	13	20	269	Rp1/4"	18	80	38	14	13	0.39 kN	103.110.131.044.100.
130	514	55	13	20	329	Rp1/4"	18	80	38	14	13	0.39 kN	103.110.131.044.130.
150	574	55	13	20	369	Rp1/4"	18	80	38	14	13	0.39 kN	103.110.131.044.150.

S = stroke, * at 1 bar pressure

Nominal size 058

S	a	b	c	d	e	f	g	h	i	k	l	Force*	Order-number
36	232	70	13	20	141	Rp1/4"	18	90	38	14	13	0.72 kN	103.110.131.058.036.
50	274	70	13	20	169	Rp1/4"	18	90	38	14	13	0.72 kN	103.110.131.058.050.
65	319	70	13	20	199	Rp1/4"	18	90	38	14	13	0.72 kN	103.110.131.058.065.
80	364	70	13	20	229	Rp1/4"	18	90	38	14	13	0.72 kN	103.110.131.058.080.
100	424	70	13	20	269	Rp1/4"	18	90	38	14	13	0.72 kN	103.110.131.058.100.
130	514	70	13	20	329	Rp1/4"	18	90	38	14	13	0.72 kN	103.110.131.058.130.
150	574	70	13	20	369	Rp1/4"	18	90	38	14	13	0.72 kN	103.110.131.058.150.

S = stroke, * at 1 bar pressure

Complete the Order-number:

Example: 103.110.131.058.036.??? No. Force connection (S.10).?? No. Cylinder rod (S.11)!

We reserve the right to make changes which are in the interest of technical progress.

© by WMA Schmidt & Bittner GmbH, Baumwaide 23, D-74360 Illfeld-Auenstein, Tel. +49 7062 9066-0, Fax +49 7062 9066-20

info@wma-sb.de or wma-sb@t-online.de, http://www.wma-sb.de

Cylinder-Bottom flange-7



Welding cylinder

Bottom flange

Version: 2011-01

unilateral air connection,
three-stage pressurized

undamped

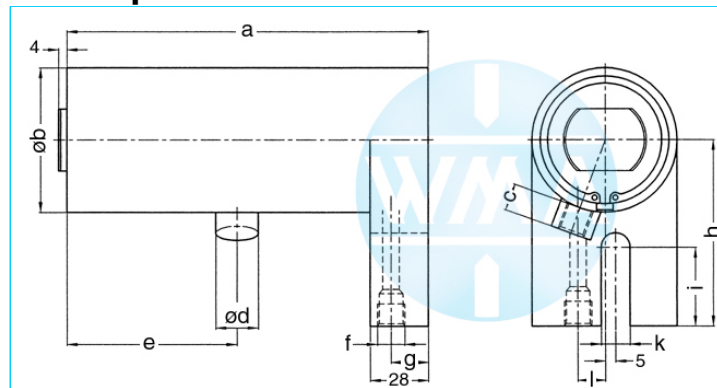

Nominal size 070

S	a	b	c	d	e	f	g	h	i	k	l	Force*	Order-number
36	276	90	16	25	169	Rp3/8"	17	110	49	17	16	1.04 kN	103.110.131.070.036.
50	318	90	16	25	197	Rp3/8"	17	110	49	17	16	1.04 kN	103.110.131.070.050.
65	363	90	16	25	227	Rp3/8"	17	110	49	17	16	1.04 kN	103.110.131.070.065.
80	408	90	16	25	257	Rp3/8"	17	110	49	17	16	1.04 kN	103.110.131.070.080.
100	468	90	16	25	297	Rp3/8"	17	110	49	17	16	1.04 kN	103.110.131.070.100.
130	558	90	16	25	357	Rp3/8"	17	110	49	17	16	1.04 kN	103.110.131.070.130.
150	618	90	16	25	397	Rp3/8"	17	110	49	17	16	1.04 kN	103.110.131.070.150.

S = stroke, * at 1 bar pressure

Nominal size 080

S	a	b	c	d	e	f	g	h	i	k	l	Force*	Order-number
36	276	100	16	25	169	Rp3/8"	17	120	49	17	16	1.4 kN	103.110.131.080.036.
50	318	100	16	25	197	Rp3/8"	17	120	49	17	16	1.4 kN	103.110.131.080.050.
65	363	100	16	25	227	Rp3/8"	17	120	49	17	16	1.4 kN	103.110.131.080.065.
80	408	100	16	25	257	Rp3/8"	17	120	49	17	16	1.4 kN	103.110.131.080.080.
100	468	100	16	25	297	Rp3/8"	17	120	49	17	16	1.4 kN	103.110.131.080.100.
130	558	100	16	25	357	Rp3/8"	17	120	49	17	16	1.4 kN	103.110.131.080.130.
150	618	100	16	25	397	Rp3/8"	17	120	49	17	16	1.4 kN	103.110.131.080.150.

S = stroke, * at 1 bar pressure

Nominal size 090

S	a	b	c	d	e	f	g	h	i	k	l	Force*	Order-number
36	276	110	16	25	169	Rp3/8"	17	130	49	17	16	1.8 kN	103.110.131.090.036.
50	318	110	16	25	197	Rp3/8"	17	130	49	17	16	1.8 kN	103.110.131.090.050.
65	363	110	16	25	227	Rp3/8"	17	130	49	17	16	1.8 kN	103.110.131.090.065.
80	408	110	16	25	257	Rp3/8"	17	130	49	17	16	1.8 kN	103.110.131.090.080.
100	468	110	16	25	297	Rp3/8"	17	130	49	17	16	1.8 kN	103.110.131.090.100.
130	558	110	16	25	357	Rp3/8"	17	130	49	17	16	1.8 kN	103.110.131.090.130.
150	618	110	16	25	397	Rp3/8"	17	130	49	17	16	1.8 kN	103.110.131.090.150.

S = stroke, * at 1 bar pressure

Complete the Order-number:

Example: 103.110.131.080.036.??? No. Force connection (S.10).?? No. Cylinder rod (S.11)!

We reserve the right to make changes which are in the interest of technical progress.

© by WMA Schmidt & Bittner GmbH, Baumwaide 23, D-74360 Illfeld-Auenstein, Tel. +49 7062 9066-0, Fax +49 7062 9066-20

info@wma-sb.de or wma-sb@t-online.de, <http://www.wma-sb.de>

Cylinder-Bottom flange-8



Welding cylinder

Bottom flange

Version: 2011-01

unilateral air connection,
three-stage pressurized

damped independent of stroke

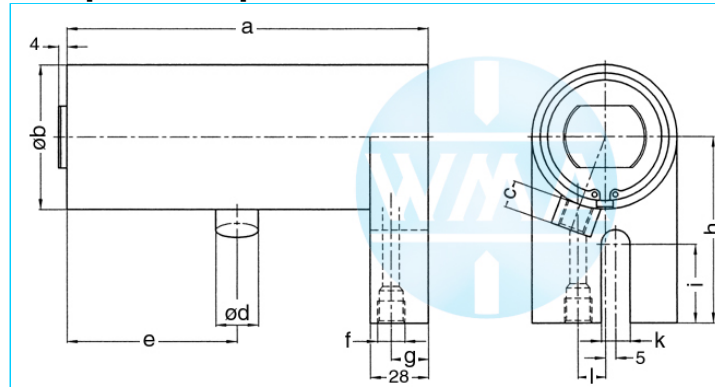

Nominal size 070

S	a	b	c	d	e	f	g	h	i	k	l	Force*	Order-number
36	276	90	16	25	169	Rp3/8"	17	110	49	17	16	1.04 kN	103.110.132.070.036.
50	318	90	16	25	197	Rp3/8"	17	110	49	17	16	1.04 kN	103.110.132.070.050.
65	363	90	16	25	227	Rp3/8"	17	110	49	17	16	1.04 kN	103.110.132.070.065.
80	408	90	16	25	257	Rp3/8"	17	110	49	17	16	1.04 kN	103.110.132.070.080.
100	468	90	16	25	297	Rp3/8"	17	110	49	17	16	1.04 kN	103.110.132.070.100.
130	558	90	16	25	357	Rp3/8"	17	110	49	17	16	1.04 kN	103.110.132.070.130.
150	618	90	16	25	397	Rp3/8"	17	110	49	17	16	1.04 kN	103.110.132.070.150.

S = stroke, * at 1 bar pressure

Nominal size 080

S	a	b	c	d	e	f	g	h	i	k	l	Force*	Order-number
36	276	100	16	25	169	Rp3/8"	17	120	49	17	16	1.4 kN	103.110.132.080.036.
50	318	100	16	25	197	Rp3/8"	17	120	49	17	16	1.4 kN	103.110.132.080.050.
65	363	100	16	25	227	Rp3/8"	17	120	49	17	16	1.4 kN	103.110.132.080.065.
80	408	100	16	25	257	Rp3/8"	17	120	49	17	16	1.4 kN	103.110.132.080.080.
100	468	100	16	25	297	Rp3/8"	17	120	49	17	16	1.4 kN	103.110.132.080.100.
130	558	100	16	25	357	Rp3/8"	17	120	49	17	16	1.4 kN	103.110.132.080.130.
150	618	100	16	25	397	Rp3/8"	17	120	49	17	16	1.4 kN	103.110.132.080.150.

S = stroke, * at 1 bar pressure

Nominal size 090

S	a	b	c	d	e	f	g	h	i	k	l	Force*	Order-number
36	276	110	16	25	169	Rp3/8"	17	130	49	17	16	1.8 kN	103.110.132.090.036.
50	318	110	16	25	197	Rp3/8"	17	130	49	17	16	1.8 kN	103.110.132.090.050.
65	363	110	16	25	227	Rp3/8"	17	130	49	17	16	1.8 kN	103.110.132.090.065.
80	408	110	16	25	257	Rp3/8"	17	130	49	17	16	1.8 kN	103.110.132.090.080.
100	468	110	16	25	297	Rp3/8"	17	130	49	17	16	1.8 kN	103.110.132.090.100.
130	558	110	16	25	357	Rp3/8"	17	130	49	17	16	1.8 kN	103.110.132.090.130.
150	618	110	16	25	397	Rp3/8"	17	130	49	17	16	1.8 kN	103.110.132.090.150.

S = stroke, * at 1 bar pressure

Complete the Order-number:

Example: 103.110.132.070.130.??? No. Force connection (S.10).?? No. Cylinder rod (S.11)!

We reserve the right to make changes which are in the interest of technical progress.

© by WMA Schmidt & Bittner GmbH, Baumwaide 23, D-74360 Illfeld-Auenstein, Tel. +49 7062 9066-0, Fax +49 7062 9066-20

info@wma-sb.de or wma-sb@t-online.de, <http://www.wma-sb.de>

Cylinder-Bottom flange-9



Welding cylinder

Bottom flange

Version: 2011-01

Force connection

Write the number (with point) from the selected Force connection direct behind the Order-number of the cylinder and complete the whole Order-number with the chosen number of the Cylinder rod.

Example: 103.110.131.058.036.401.?? No. Cylinder rod (S.11)

Internal cone

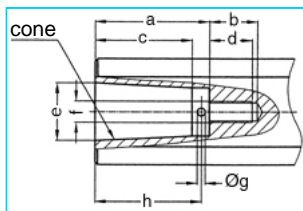

a	b	c	d	e	cone	f	g	h	No.
33	18	27.0	16	17.780	MK2	M8	3	30	101.
42	18	35.5	16	21.806	MK3	M8	3	39	102.
42	18	35.5	16	21.750	1:10	M8	3	39	103.

Female thread

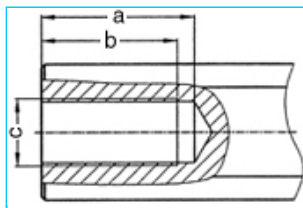

a	b	c	No.
45	40	M20 x 1.5	201.
62	58	M20 x 1.5	202.

Male thread

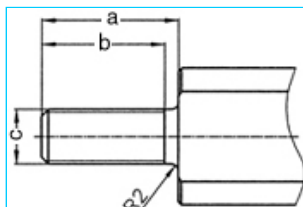

a	b	c	No.
40	36	M16 x 1.5	301.
40	36	M20 x 1.5	302.
40	36	M24 x 1.5	303.

Knurl

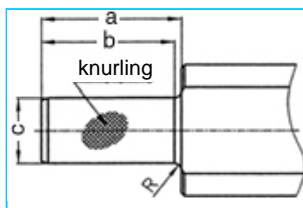

a	b	c	Knurling	R	No.
42	40	20 ¹⁷	1 x 0.2 DIN 82	2	401.
42	42	25 ¹⁷	1 x 0.2 DIN 82	-	402.

We reserve the right to make changes which are in the interest of technical progress.

© by WMA Schmidt & Bittner GmbH, Baumwaide 23, D-74360 Illfeld-Auenstein, Tel. +49 7062 9066-0, Fax +49 7062 9066-20

info@wma-sb.de or wma-sb@t-online.de, <http://www.wma-sb.de>

Cylinder-Bottom flange-10



Welding cylinder

Bottom flange

Version: 2011-01

Cylinder rod

flattened and rotation locked

Complete the Order-number with the selected number of the chosen cylinder rod.

Example: 103.110.131.058.036.401.03

For piston diameter

70, 80, 90

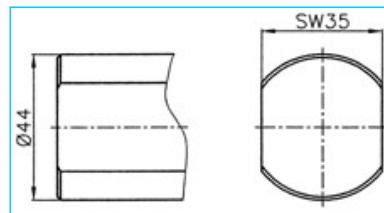

No. 00

For piston diameter

38, 44, 58

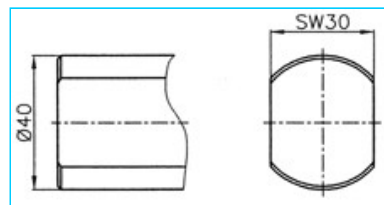

No. 01

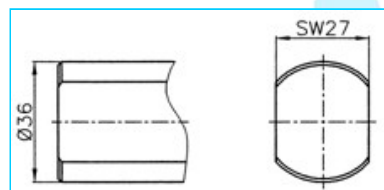

No. 02

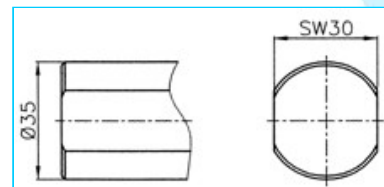

No. 03



Welding cylinder

Bottom flange

Version: 2011-01

Electrode holder for welding cylinders

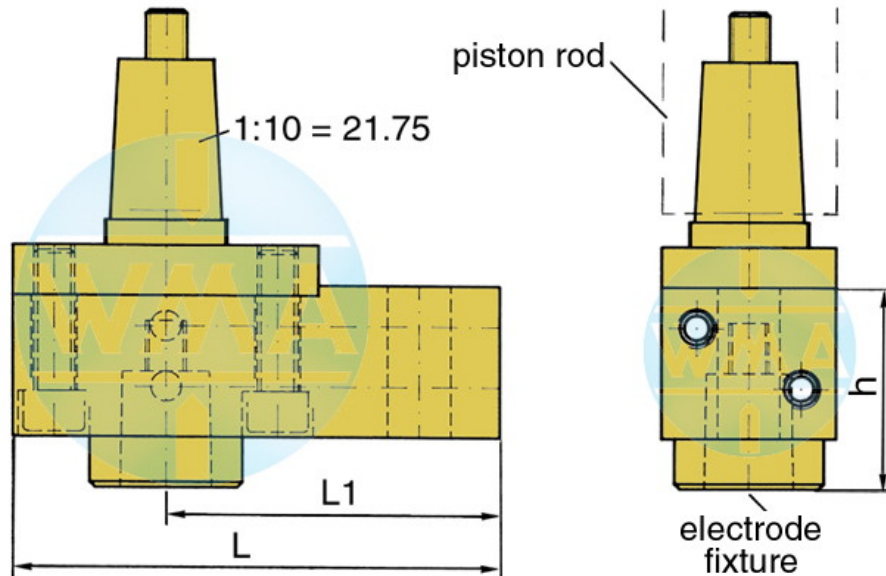

Piston Ø	L	L1	Water connection
38	95	65	possible on both sides
44	95	65	possible on both sides
58	110	80	possible on both sides
70	110	80	possible on both sides
80	120	90	possible on both sides
90	120	90	possible on both sides

Available cones for the electrode fixture

cone	Ø d	h
1 : 10	9.8	39
1 : 10	12.0	39
1 : 10	12.7	39
1 : 10	15.5	39
1 : 10	15.75	39
1 : 10	17.75	50
1 : 10	19.0	50
MK 1	12.065	39
MK 2	17.781	50

Further cones available on request!



Welding cylinder

Bottom flange

Version: 2011-01

Electrode holder

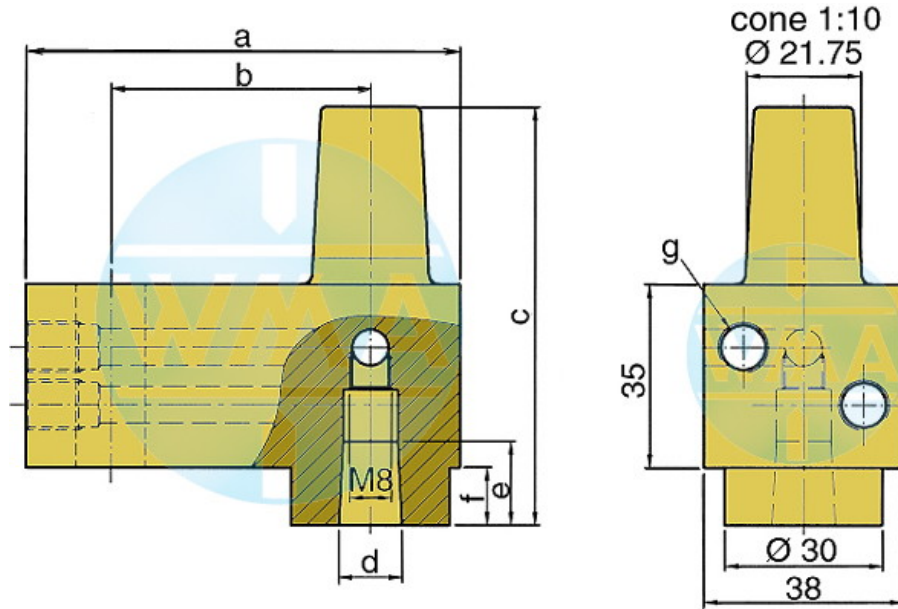

This electrode holder is main used in welding machines with variable and fast-change electrode shafts.

a	b	c	d	e	f	g	Order-number	
82	49	80	1:10=12.00	16	16	11	M10 x 1 or R 1/8"	L60051080-000
82	49	80	MK1	16	16	11	M10 x 1 or R 1/8"	L60091080-000
82	49	80	1:10=15.75	20	20	11	M10 x 1 or R 1/8"	L60131080-001
82	49	80	1:10=18	20	20	11	M10 x 1 or R 1/8"	L60061080-000
82	49	80	MK2	20	20	11	M10 x 1 or R 1/8"	L60101080-000
82	49	90	1:10=21.75	31	31	21	M10 x 1 or R 1/8"	L60221080-000
82	49	90	MK3	31	31	21	M10 x 1 or R 1/8"	L60111080-000
97	64	90	1:10=21.75	31	31	21	M10 x 1 or R 1/8"	L60221090-000
97	64	90	MK3	31	31	21	M10 x 1 or R 1/8"	L60111090-000
107	74	90	1:10=21.75	31	31	21	M10 x 1 or R 1/8"	L60221090-001
107	74	90	MK3	31	31	21	M10 x 1 or R 1/8"	L60111090-001

We reserve the right to make changes which are in the interest of technical progress.

© by WMA Schmidt & Bittner GmbH, Baumwaide 23, D-74360 Illfeld-Auenstein, Tel. +49 7062 9066-0, Fax +49 7062 9066-20

info@wma-sb.de or wma-sb@t-online.de, <http://www.wma-sb.de>