



Schweißzylinder

Triplex

Stand: 10.2008

**zweiseitiger Luftanschluss,
zweistufig beaufschlagt**

ungedämpft

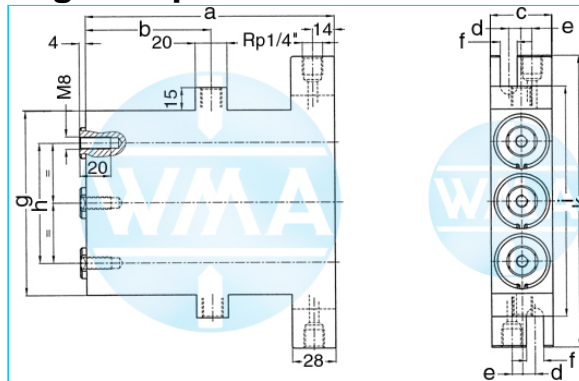

Nenngröße 025

Hub	a	b	c	d	e	f	g	h	i	k	Kraft*	Bestellnummer
36	160	81	30	7	7	11	90	60	115	150	0,26 kN	108.120.121.025.036.20
50	188	95	30	7	7	11	90	60	115	150	0,26 kN	108.120.121.025.050.20
65	218	110	30	7	7	11	90	60	115	150	0,26 kN	108.120.121.025.065.20
80	248	125	30	7	7	11	90	60	115	150	0,26 kN	108.120.121.025.080.20
100	288	145	30	7	7	11	90	60	115	150	0,26 kN	108.120.121.025.100.20
130	348	175	30	7	7	11	90	60	115	150	0,26 kN	108.120.121.025.130.20
150	388	195	30	7	7	11	90	60	115	150	0,26 kN	108.120.121.025.150.20

* bei 1 bar Druck

Nenngröße 032

Hub	a	b	c	d	e	f	g	h	i	k	Kraft*	Bestellnummer
36	160	81	40	8	7	11	120	78	150	190	0,45 kN	108.120.121.032.036.20
50	188	95	40	8	7	11	120	78	150	190	0,45 kN	108.120.121.032.050.20
65	218	110	40	8	7	11	120	78	150	190	0,45 kN	108.120.121.032.065.20
80	248	125	40	8	7	11	120	78	150	190	0,45 kN	108.120.121.032.080.20
100	288	145	40	8	7	11	120	78	150	190	0,45 kN	108.120.121.032.100.20
130	348	175	40	8	7	11	120	78	150	190	0,45 kN	108.120.121.032.130.20
150	388	195	40	8	7	11	120	78	150	190	0,45 kN	108.120.121.032.150.20

* bei 1 bar Druck

Nenngröße 034

Hub	a	b	c	d	e	f	g	h	i	k	Kraft*	Bestellnummer
36	160	81	40	8	7	11	120	78	150	190	0,51 kN	108.120.121.034.036.20
50	188	95	40	8	7	11	120	78	150	190	0,51 kN	108.120.121.034.050.20
65	218	110	40	8	7	11	120	78	150	190	0,51 kN	108.120.121.034.065.20
80	248	125	40	8	7	11	120	78	150	190	0,51 kN	108.120.121.034.080.20
100	288	145	40	8	7	11	120	78	150	190	0,51 kN	108.120.121.034.100.20
130	348	175	40	8	7	11	120	78	150	190	0,51 kN	108.120.121.034.130.20
150	388	195	40	8	7	11	120	78	150	190	0,51 kN	108.120.121.034.150.20

* bei 1 bar Druck

Technische Änderungen, die dem Fortschritt dienen, behalten wir uns vor.

© by WMA Schmidt & Bittner GmbH, Baumwaide 23, D-74360 Ilsfeld-Auenstein, Tel. +49 7062 9066-0, Fax +49 7062 9066-20

info@wma-sb.de oder wma-sb@t-online.de, <http://www.wma-sb.de>

Zylinder-Triplex-1



Schweißzylinder

Triplex

Stand: 10.2008

**zweiseitiger Luftanschluss,
zweistufig beaufschlagt**

ungedämpft

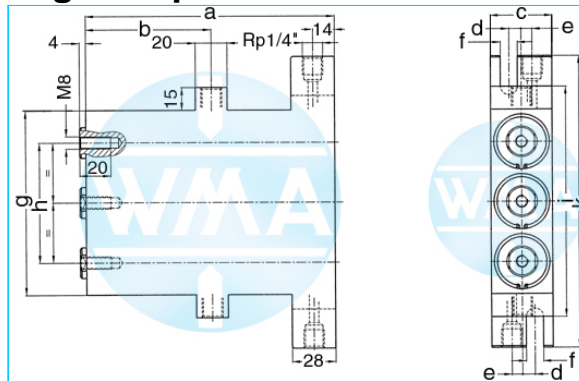

Nenngröße 038

Hub	a	b	c	d	e	f	g	h	i	k	Kraft*	Bestellnummer
36	160	81	48	10	8	13	150	100	174	210	0,6 kN	108.120.121.038.036.30
50	188	95	48	10	8	13	150	100	174	210	0,6 kN	108.120.121.038.050.30
65	218	110	48	10	8	13	150	100	174	210	0,6 kN	108.120.121.038.065.30
80	248	125	48	10	8	13	150	100	174	210	0,6 kN	108.120.121.038.080.30
100	288	145	48	10	8	13	150	100	174	210	0,6 kN	108.120.121.038.100.30
130	348	175	48	10	8	13	150	100	174	210	0,6 kN	108.120.121.038.130.30
150	388	195	48	10	8	13	150	100	174	210	0,6 kN	108.120.121.038.150.30

* bei 1 bar Druck

Nenngröße 044

Hub	a	b	c	d	e	f	g	h	i	k	Kraft*	Bestellnummer
36	160	81	52	10	8	13	152	100	174	210	0,84 kN	108.120.121.044.036.30
50	188	95	52	10	8	13	152	100	174	210	0,84 kN	108.120.121.044.050.30
65	218	110	52	10	8	13	152	100	174	210	0,84 kN	108.120.121.044.065.30
80	248	125	52	10	8	13	152	100	174	210	0,84 kN	108.120.121.044.080.30
100	288	145	52	10	8	13	152	100	174	210	0,84 kN	108.120.121.044.100.30
130	348	175	52	10	8	13	152	100	174	210	0,84 kN	108.120.121.044.130.30
150	388	195	52	10	8	13	152	100	174	210	0,84 kN	108.120.121.044.150.30

* bei 1 bar Druck

Nenngröße 058

Hub	a	b	c	d	e	f	g	h	i	k	Kraft*	Bestellnummer
36	160	81	70	10	8	13	210	140	234	260	1,5 kN	108.120.121.058.036.30
50	188	95	70	10	8	13	210	140	234	260	1,5 kN	108.120.121.058.050.30
65	218	110	70	10	8	13	210	140	234	260	1,5 kN	108.120.121.058.065.30
80	248	125	70	10	8	13	210	140	234	260	1,5 kN	108.120.121.058.080.30
100	288	145	70	10	8	13	210	140	234	260	1,5 kN	108.120.121.058.100.30
130	348	175	70	10	8	13	210	140	234	260	1,5 kN	108.120.121.058.130.30
150	388	195	70	10	8	13	210	140	234	260	1,5 kN	108.120.121.058.150.30

* bei 1 bar Druck

Technische Änderungen, die dem Fortschritt dienen, behalten wir uns vor.

© by WMA Schmidt & Bittner GmbH, Baumwaide 23, D-74360 Ilsfeld-Auenstein, Tel. +49 7062 9066-0, Fax +49 7062 9066-20

info@wma-sb.de oder wma-sb@t-online.de, <http://www.wma-sb.de>

Zylinder-Triplex-2



Schweißzylinder

Triplex

Stand: 10.2008

**zweiseitiger Luftanschluss,
dreistufig beaufschlagt**

ungedämpft

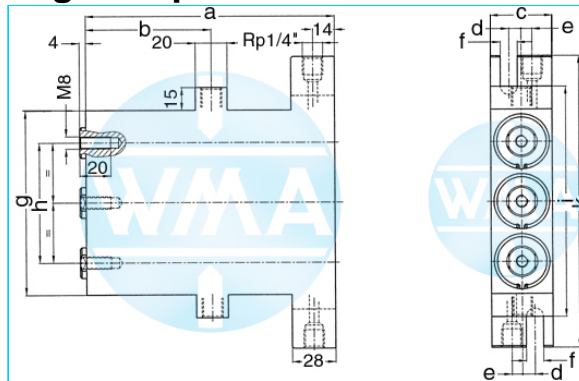

Nenngröße 025

Hub	a	b	c	d	e	f	g	h	i	k	Kraft*	Bestellnummer
36	217	138	30	7	7	11	90	60	115	150	0,35 kN	108.120.131.025.036.20
50	259	166	30	7	7	11	90	60	115	150	0,35 kN	108.120.131.025.050.20
65	304	196	30	7	7	11	90	60	115	150	0,35 kN	108.120.131.025.065.20
80	349	226	30	7	7	11	90	60	115	150	0,35 kN	108.120.131.025.080.20
100	409	266	30	7	7	11	90	60	115	150	0,35 kN	108.120.131.025.100.20
130	499	326	30	7	7	11	90	60	115	150	0,35 kN	108.120.131.025.130.20
150	559	366	30	7	7	11	90	60	115	150	0,35 kN	108.120.131.025.150.20

* bei 1 bar Druck

Nenngröße 032

Hub	a	b	c	d	e	f	g	h	i	k	Kraft*	Bestellnummer
36	217	138	40	8	7	11	120	78	150	190	0,63 kN	108.120.131.032.036.20
50	259	166	40	8	7	11	120	78	150	190	0,63 kN	108.120.131.032.050.20
65	304	196	40	8	7	11	120	78	150	190	0,63 kN	108.120.131.032.065.20
80	349	226	40	8	7	11	120	78	150	190	0,63 kN	108.120.131.032.080.20
100	409	266	40	8	7	11	120	78	150	190	0,63 kN	108.120.131.032.100.20
130	499	326	40	8	7	11	120	78	150	190	0,63 kN	108.120.131.032.130.20
150	559	366	40	8	7	11	120	78	150	190	0,63 kN	108.120.131.032.150.20

* bei 1 bar Druck

Nenngröße 034

Hub	a	b	c	d	e	f	g	h	i	k	Kraft*	Bestellnummer
36	217	138	40	8	7	11	120	78	150	190	0,72 kN	108.120.131.034.036.20
50	259	166	40	8	7	11	120	78	150	190	0,72 kN	108.120.131.034.050.20
65	304	196	40	8	7	11	120	78	150	190	0,72 kN	108.120.131.034.065.20
80	349	226	40	8	7	11	120	78	150	190	0,72 kN	108.120.131.034.080.20
100	409	266	40	8	7	11	120	78	150	190	0,72 kN	108.120.131.034.100.20
130	499	326	40	8	7	11	120	78	150	190	0,72 kN	108.120.131.034.130.20
150	559	366	40	8	7	11	120	78	150	190	0,72 kN	108.120.131.034.150.20

* bei 1 bar Druck

Technische Änderungen, die dem Fortschritt dienen, behalten wir uns vor.

© by WMA Schmidt & Bittner GmbH, Baumwaide 23, D-74360 Ilsfeld-Auenstein, Tel. +49 7062 9066-0, Fax +49 7062 9066-20
 info@wma-sb.de oder wma-sb@t-online.de, http://www.wma-sb.de

Zylinder-Triplex-3



Schweißzylinder

Triplex

Stand: 10.2008

**zweiseitiger Luftanschluss,
dreistufig beaufschlagt**

ungedämpft

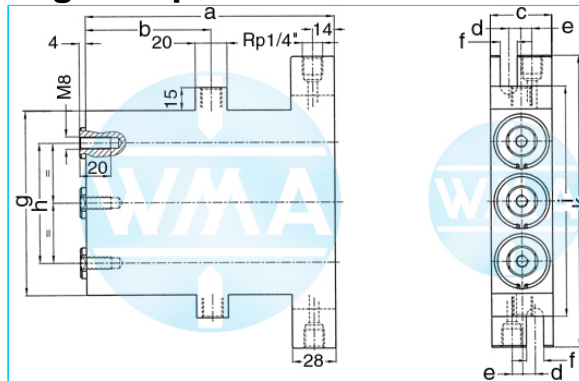

Nenngröße 038

Hub	a	b	c	d	e	f	g	h	i	k	Kraft*	Bestellnummer
36	217	138	48	10	8	13	150	100	174	210	0,84 kN	108.120.131.038.036.30
50	259	166	48	10	8	13	150	100	174	210	0,84 kN	108.120.131.038.050.30
65	304	196	48	10	8	13	150	100	174	210	0,84 kN	108.120.131.038.065.30
80	349	226	48	10	8	13	150	100	174	210	0,84 kN	108.120.131.038.080.30
100	409	266	48	10	8	13	150	100	174	210	0,84 kN	108.120.131.038.100.30
130	499	326	48	10	8	13	150	100	174	210	0,84 kN	108.120.131.038.130.30
150	559	366	48	10	8	13	150	100	174	210	0,84 kN	108.120.131.038.150.30

* bei 1 bar Druck

Nenngröße 044

Hub	a	b	c	d	e	f	g	h	i	k	Kraft*	Bestellnummer
36	217	138	52	10	8	13	152	100	174	210	1,17 kN	108.120.131.044.036.30
50	259	166	52	10	8	13	152	100	174	210	1,17 kN	108.120.131.044.050.30
65	304	196	52	10	8	13	152	100	174	210	1,17 kN	108.120.131.044.065.30
80	349	226	52	10	8	13	152	100	174	210	1,17 kN	108.120.131.044.080.30
100	409	266	52	10	8	13	152	100	174	210	1,17 kN	108.120.131.044.100.30
130	499	326	52	10	8	13	152	100	174	210	1,17 kN	108.120.131.044.130.30
150	559	366	52	10	8	13	152	100	174	210	1,17 kN	108.120.131.044.150.30

* bei 1 bar Druck

Nenngröße 058

Hub	a	b	c	d	e	f	g	h	i	k	Kraft*	Bestellnummer
36	217	138	70	10	8	13	210	140	234	260	2,16 kN	108.120.131.058.036.30
50	259	166	70	10	8	13	210	140	234	260	2,16 kN	108.120.131.058.050.30
65	304	196	70	10	8	13	210	140	234	260	2,16 kN	108.120.131.058.065.30
80	349	226	70	10	8	13	210	140	234	260	2,16 kN	108.120.131.058.080.30
100	409	266	70	10	8	13	210	140	234	260	2,16 kN	108.120.131.058.100.30
130	499	326	70	10	8	13	210	140	234	260	2,16 kN	108.120.131.058.130.30
150	559	366	70	10	8	13	210	140	234	260	2,16 kN	108.120.131.058.150.30

* bei 1 bar Druck

Technische Änderungen, die dem Fortschritt dienen, behalten wir uns vor.

© by WMA Schmidt & Bittner GmbH, Baumwaide 23, D-74360 Ilsfeld-Auenstein, Tel. +49 7062 9066-0, Fax +49 7062 9066-20

info@wma-sb.de oder wma-sb@t-online.de, http://www.wma-sb.de

Zylinder-Triplex-4



Schweißzylinder

Triplex

Stand: 10.2008

Halteplatte für Triplexzylinder

Für Zylinderkolbendurchmesser (Nenngröße) 25,32, 34, 38, 44 und 58 mm

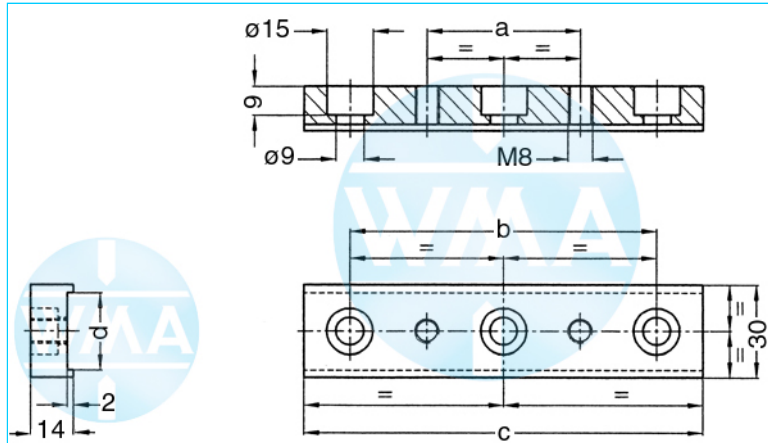

**Kolben-
durchmesser**

	a	b	c	d
25	--	60	80	17
32, 34	50	78	98	17
38, 44	50	100	130	25
58	50	140	170	25

Elektrodenhalter für Triplexzylinder

Für Zylinderkolbendurchmesser (Nenngröße) 25,32, 34, 38, 44 und 58 mm

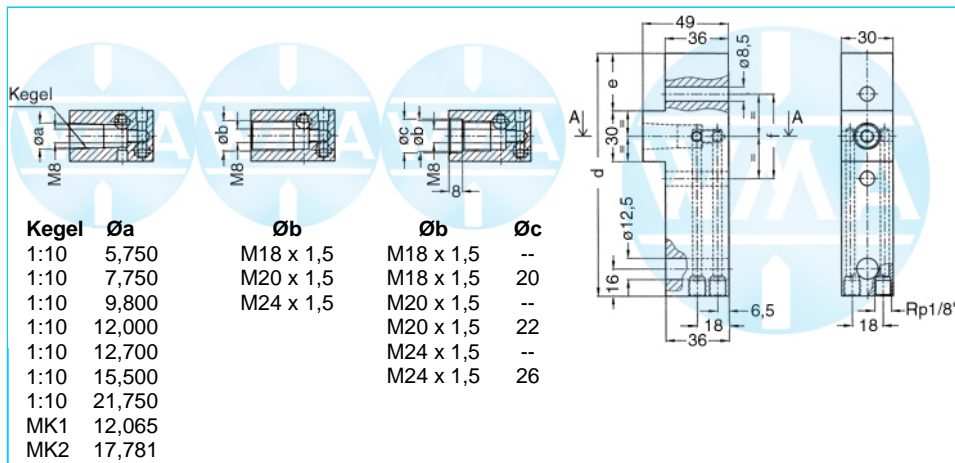

Kegel	Øa	Øb	Øb	Øc
1:10	5,750	M18 x 1,5	M18 x 1,5	--
1:10	7,750	M20 x 1,5	M18 x 1,5	20
1:10	9,800	M24 x 1,5	M20 x 1,5	--
1:10	12,000		M20 x 1,5	22
1:10	12,700		M24 x 1,5	--
1:10	15,500		M24 x 1,5	26
1:10	21,750			
MK1	12,065			
MK2	17,781			

Kolben-

durchmesser	d	e	f
25	119	25	60
32, 34	143	34	50
38, 44	175	50	50
58	224	70	50

Technische Änderungen, die dem Fortschritt dienen, behalten wir uns vor.

© by WMA Schmidt & Bittner GmbH, Baumwaide 23, D-74360 Ilsfeld-Auenstein, Tel. +49 7062 9066-0, Fax +49 7062 9066-20
info@wma-sb.de oder wma-sb@t-online.de, http://www.wma-sb.de

Zylinder-Triplex-5