



# WMP15

Version: 01-2011



**Single-hand push welding machine for automotive engineering, tank and steel cabinet engineering, sheet metal processing, wire industry and for micro welding guns**

- trouble-free welding of all types of sheet metal
- faultless welding of galvanized sheet using slope control and lowering current control
- air-cooled, equipped for external water cooling
- floor-mounted appliance or mobile appliance available
- easy replacement of tools due to standardized rotatable connections
- respectively only one plug for welding current line, control wire and water cooling
- repeatable welding results at any time with installed automatic energy control
- quick electrode removal
- rugged body with different retainers for tube , cable, etc.

	WMP15-01, -02	WMP15S
Nominal capacity (at 50% ED)	15 kVA	36 kVA
Permissible voltage drop at nominal capacity	6%	6%
Nominal primary voltage	400 V	400 V
Supply frequency	50 Hz	50 Hz
Settings	4	-
Welding capacity for steel*	1.0 + 1.0 mm	1.0 + 1.0 mm
Connection section	4 (3) x 6 mm <sup>2</sup>	4 (3) x 16 mm <sup>2</sup>
Secondary short circuit current at cable section 100 mm <sup>2</sup> cable spacing 100 mm cable length 2 m	4.5 kA	6.3 V
Fuse, delayed action, at welding cable length of 2 m	35 A	63 A
Secondary open-circuit voltage	5.2-8.2 V	6.3 V
Cooling water requirement for water cooling	200 l/h	200 l/h
Dimensions: Length	650 mm	650 mm
Width	300 mm	300 mm
Height	450 mm	450 mm
Weight	60 kg	60 kg

\*blank and equally strong or any strength material

## Order-numbers:

WMP15-01 (stationary): **XR0.451.C09B000**  
WMP15-02 (mobile): **XR0.451.C10B000**  
WMP15S (mobile): **XR0.418.C01B000**

We reserve the right to make changes which are in the interest of technical progress.

© by WMA Schmidt & Bittner GmbH, Baumwaide 23, D-74360 Ilsfeld-Auenstein, Tel. +49 7062 9066-0, Fax +49 7062 9066-20  
info@wma-sb.de or wma-sb@t-online.de, <http://www.wma-sb.de>

WMP15-1



# WMP15

Version: 01-2011

## WMP15 Standard accessories:

**Set of cable**, 2 m long, cross-section 100 mm<sup>2</sup>, air or water cooled (further dimensions of the cable are available, of course!);

### Gun welding head type PP1

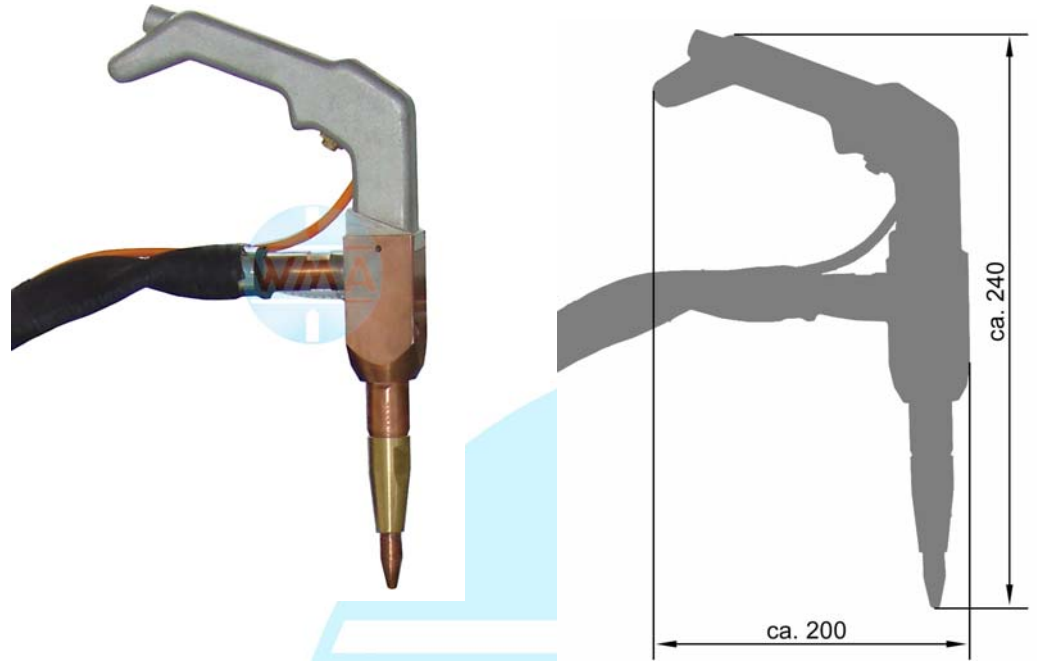

Gun welding head PP1  
water or air cooled  
Order-number:  
**XR1.401.000**

### Ground clamp

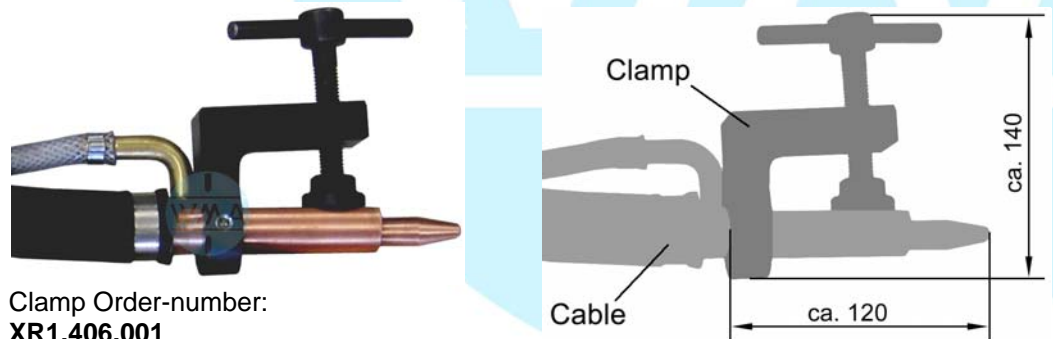

Clamp Order-number:  
**XR1.406.001**

Cable Order-number:  
**OW1002000-001**

We reserve the right to make changes which are in the interest of technical progress.

© by WMA Schmidt & Bittner GmbH, Baumwaide 23, D-74360 Ilfeld-Auenstein, Tel. +49 7062 9066-0, Fax +49 7062 9066-20  
info@wma-sb.de or wma-sb@t-online.de, <http://www.wma-sb.de>

**WMP15-2**



# WMP15

Version: 01-2011

## optional accessories for WMP15:

Micro-spot-welder: XR1.401.031B000



Ground clamp: XR1.406.016

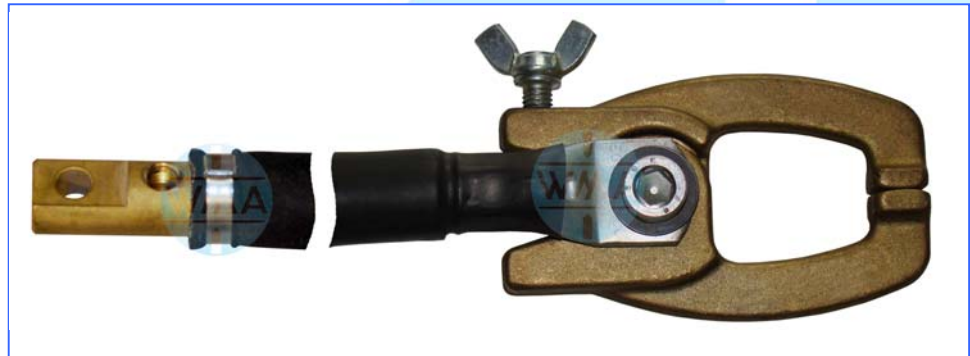

Gun welding head PP1/K: XR1.401.035B000



***Further connection parts on demand!***

We reserve the right to make changes which are in the interest of technical progress.

© by WMA Schmidt & Bittner GmbH, Baumwaide 23, D-74360 Illfeld-Auenstein, Tel. +49 7062 9066-0, Fax +49 7062 9066-20  
info@wma-sb.de or wma-sb@t-online.de, <http://www.wma-sb.de>

WMP15-3