



L 123

Version: 01-2011

pneumatically operated, water cooled* X spot welding gun

- compact design
- double stroke mechanism
- transformer, fully encapsulated in plastic
- contact pressure function in the handle
- cardan suspension
- gun with 4 m power supply cable and switch
- low-maintenance design

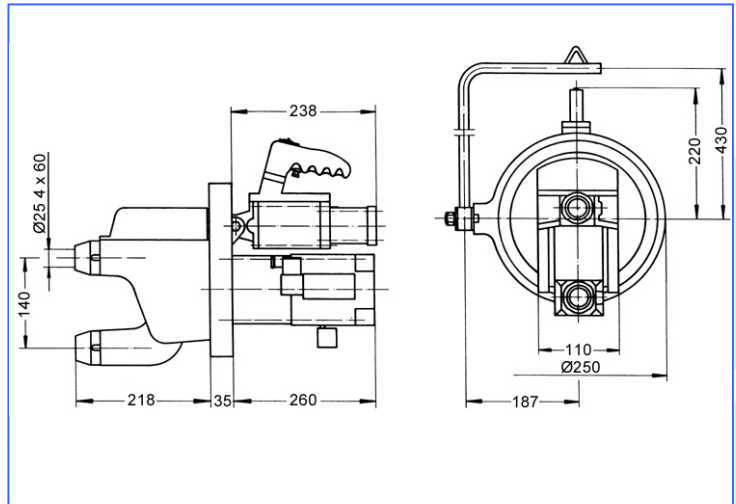

	L 123
Welding performance* (with a short depth of throat)	3 + 3 mm
Welding performance* (with a long depth of throat)	1.5 + 1.5 mm
Nominal capacity (at 50% ED)	14 kVA
Supply power	33 kVA
Connection section	6 mm ²
Fuse, delayed action	35 A
max. welding current	11.2 kA
Electrode force at 6 bar	215 daN
Vertical arm spacing**	110 mm
Depth of throat	150 mm
Weight (without electrode arms)	29 kg
Order-number	XK3.107.C01

* The welding performance data quoted refer to steel, non-continuous machining.

** Larger vertical arm spaces are possible at an additional charge.

Different welding controls can be used.

*This kit does not include a water chiller!

WMA is general distributor for NIMAK welding machines in Baden-Wuerttemberg

We reserve the right to make changes which are in the interest of technical progress.

© by WMA Schmidt & Bittner GmbH, Baumwaide 23, D-74360 Illfeld-Auenstein, Tel. +49 7062 9066-0, Fax +49 7062 9066-20
info@wma-sb.de or wma-sb@t-online.de, <http://www.wma-sb.de>

XL123-1



L 123

Version: 01-2011

Optional hand grips for spot welding guns

Standard grip



integrated grip with two additional switches



Hand grip with digital switch



Optional locking lever



We reserve the right to make changes which are in the interest of technical progress.

© by WMA Schmidt & Bittner GmbH, Baumwaide 23, D-74360 Illfeld-Auenstein, Tel. +49 7062 9066-0, Fax +49 7062 9066-20
info@wma-sb.de or wma-sb@t-online.de, <http://www.wma-sb.de>

XL123-2