



L 193 T

Version: 01-2011

pneumatically operated, water cooled* X spot welding gun

- compact design
- double stroke mechanism
- transformer, fully encapsulated in plastic
- contact pressure function in the handle
- cardan suspension
- gun with 4 m power supply cable and switch
- low-maintenance design

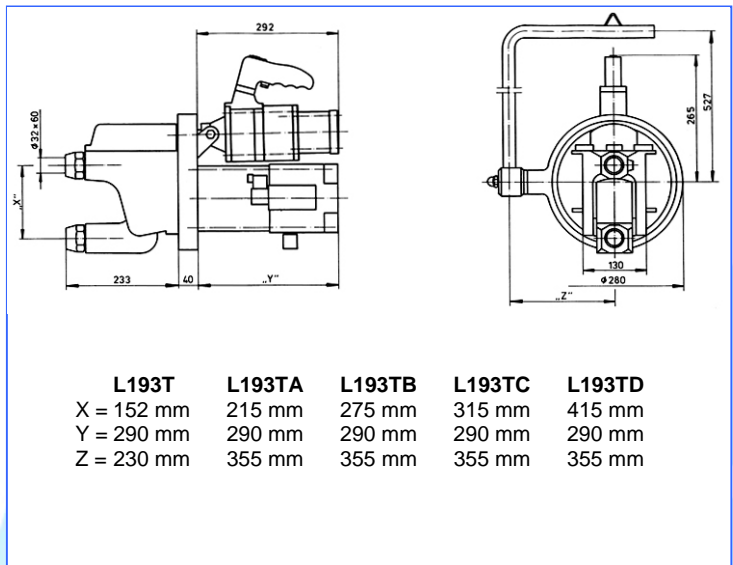
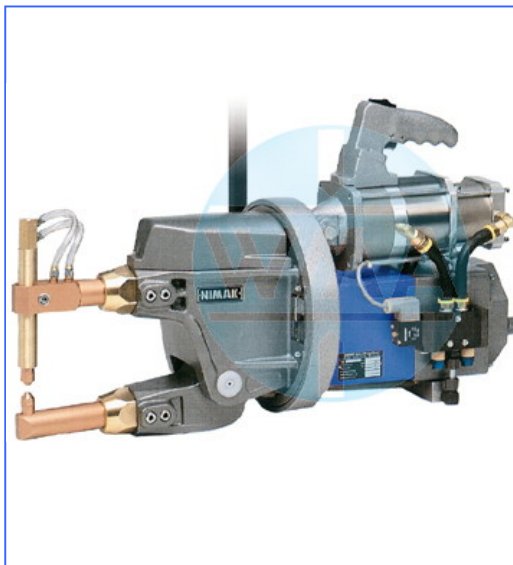

	L 193 T
Welding performance* (with a short depth of throat)	4 + 4 mm
Welding performance* (with a long depth of throat)	2 + 2 mm
Nominal capacity (at 50% ED)	28 kVA
Supply power	62.4 kVA
Connection section	16 mm ²
Fuse, delayed action	63 A
max. welding current	16.8 kA
Electrode force at 6 bar	600 daN
Vertical arm spacing**	117 mm
Depth of throat	180 mm
Weight (without electrode arms)	44 kg
Order-number	XK3.114.C00

* The welding performance data quoted refer to steel, non-continuous machining.

** Larger vertical arm spaces are possible at an additional charge.

Different welding controls can be used.

*This kit does not include a water chiller!

WMA is general distributor for NIMAK welding machines in Baden-Wuerttemberg

We reserve the right to make changes which are in the interest of technical progress.

© by WMA Schmidt & Bittner GmbH, Baumwaide 23, D-74360 Illfeld-Auenstein, Tel. +49 7062 9066-0, Fax +49 7062 9066-20
info@wma-sb.de or wma-sb@t-online.de, http://www.wma-sb.de

XL193-1



L 193 T

Version: 01-2011

Optional hand grips for spot welding guns

Standard grip



integrated grip with two additional switches



Hand grip with digital switch



Optional locking lever

