



X cable gun

Version: 01-2011

pneumatically operated, water cooled* X spot welding guns

- double cylinder
- ATL, ATM
- contact pressure 350 daN
- we supply the matching water or air cooled electrode arms in an extremely warp-resistant industrial quality.
- for various shapes see air cooled electrode arms
- other shapes available on request

At InvertaSpot™ this cable gun is also used as a vehicle gun.
Suitable electrode arms see inverta arms!

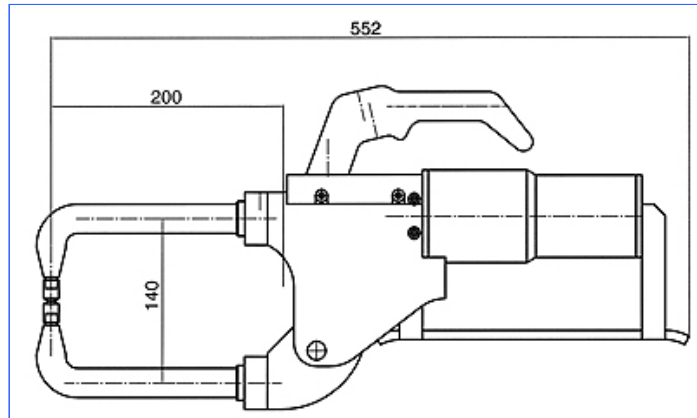
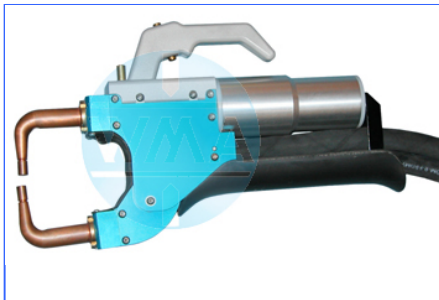

Grip can be turned 90° to the right or left and locked

Welding performance*	3 + 3 mm
Connection section	3 x 6 mm ² and mass
Electrode force	350 daN
Electrode diameter	14 mm
Welding cable length	3000 mm
Order-number	XK0.411.000

* The welding values quoted refer to steel, non-continuous machining.

Further models available on request!

*this kit does not include a water chiller!

We reserve the right to make changes which are in the interest of technical progress.

© by WMA Schmidt & Bittner GmbH, Baumwaide 23, D-74360 Illfeld-Auenstein, Tel. +49 7062 9066-0, Fax +49 7062 9066-20
info@wma-sb.de or wma-sb@t-online.de, <http://www.wma-sb.de>

X cable gun-1