



C cable gun

Version: 2011-07

pneumatically operated, water cooled* C spot welding guns

- double cylinder
- ATL, ATM
- contact pressure 480 daN
- we supply the matching water or air cooled electrode arms in an extremely warp-resistant industrial quality.
- for various shapes see air cooled electrode arms
- other shapes available on request

At InvertaSpot™ this cable gun is also used as a vehicle gun.

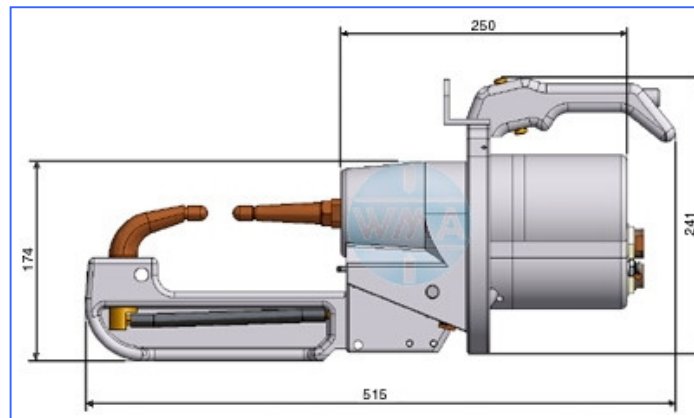
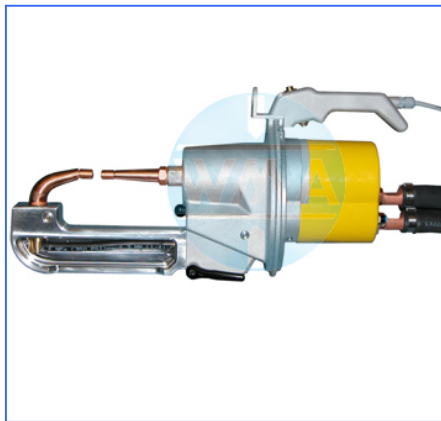

Working stroke	15 mm
Retract	15 mm
Cable cross-section	175 mm ²
Electrode force at 6 bar	480 daN
Electrode diameter	13 mm
Welding cable length	2750 mm
Weight	9.3 kg (20.5 Kg)
Order-number	XK9.412.015B000

Further variations on request!

*this kit does not include a water chiller!

We reserve the right to make changes which are in the interest of technical progress.

© by WMA Schmidt & Bittner GmbH, Baumwaide 23, D-74360 Illfeld-Auenstein, Tel. +49 7062 9066-0, Fax +49 7062 9066-20
info@wma-sb.de or wma-sb@t-online.de, <http://www.wma-sb.de>

C cable gun-1



C cable gun

Version: 2011-07

C cable gun electrode arms

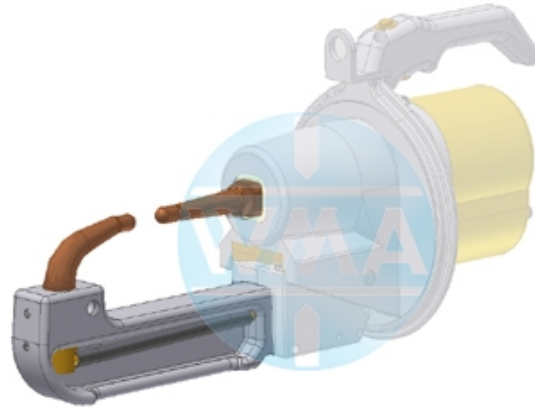

Standard arms
Order number:
XK9.412.015-B003

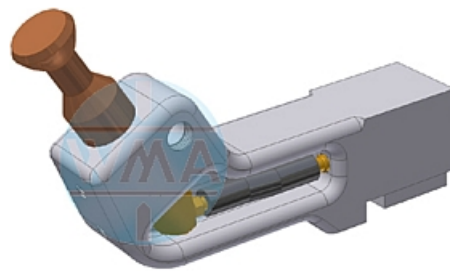

Special arm
Order number:
XK9.412.015-B014

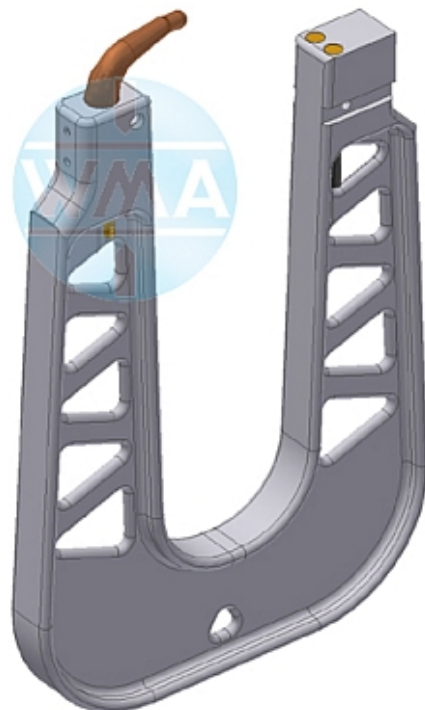

Special arm
Order number:
XK9.412.015-B011

We reserve the right to make changes which are in the interest of technical progress.

© by WMA Schmidt & Bittner GmbH, Baumwaide 23, D-74360 Illfeld-Auenstein, Tel. +49 7062 9066-0, Fax +49 7062 9066-20
info@wma-sb.de or wma-sb@t-online.de, <http://www.wma-sb.de>

C cable gun-2