



# Electrode caps

Version: 2011-01

DIN 44750

## Standard Electrode Caps

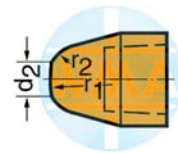
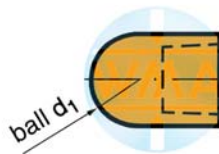
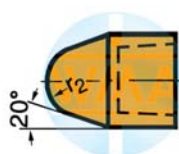
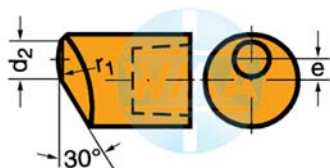
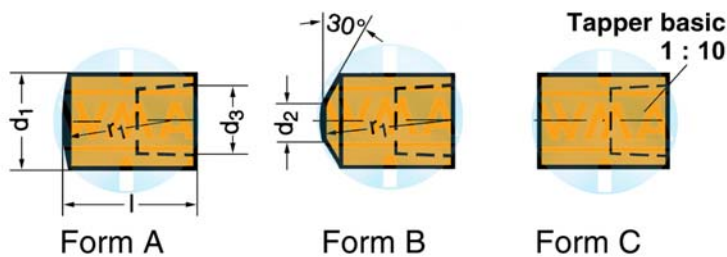

Form D

Form E

Form F

Form G

d1*	d2	d3	l	e	r1	r2	Electrode force	Form	Order-number
13	5	10	18	3	32	5	4.0 kN ( <i>Fmax</i> )	A	G660KA180-000
								B	G660KB180-000
								C	G660KC180-000
								D	G660KD180-000
								E	G660KE180-000
								F	G660KF180-000
								G	G660KG180-000

d1*	d2	d3	l	e	r1	r2	Electrode force	Form	Order-number
16	6	12	20	4	40	6	6.3 kN ( <i>Fmax</i> )	A	G650KA200-000
								B	G650KB200-000
								C	G650KC200-000
								D	G650KD200-000
								E	G650KE200-000
								F	G650KF200-000
								G	G650KG200-000

d1*	d2	d3	l	e	r1	r2	Electrode force	Form	Order-number
20	8	15	22	5	50	8	10.0 kN ( <i>Fmax</i> )	A	G652KA220-000
								B	G652KB220-000
								C	G652KC220-000
								D	G652KD220-000
								E	G652KE220-000
								F	G652KF220-000
								G	G652KG220-000

\* manufactured from rounded rods in accordance with DIN 1756.

This standard was established in conjunction with the German Association for Welding Technology (DVS).

This standard applies to those electrode caps whose electrode force, allocated the diameter d1 in the table, does not exceed *Fmax*.

We reserve the right to make changes which are in the interest of technical progress.

© by WMA Schmidt & Bittner GmbH, Baumwaide 23, D-74360 Illfeld-Auenstein, Tel. +49 7062 9066-0, Fax +49 7062 9066-20  
 info@wma-sb.de or wma-sb@t-online.de, http://www.wma-sb.de

Electrode caps-1



# Electrode caps

Version: 2011-01

## More caps (selection)

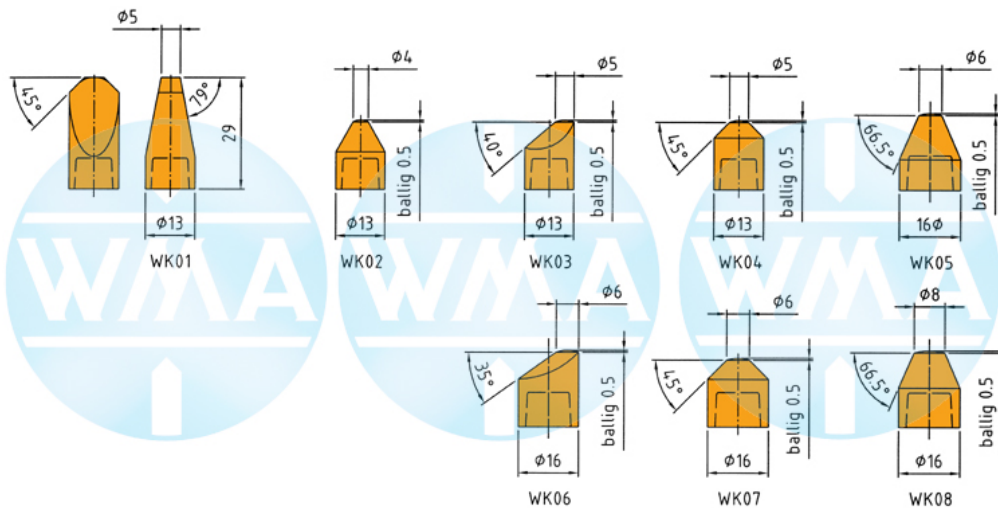

## Order-numbers:

WK01 =	G660KX280-000
WK02 =	G660KB180-020
Wk03 =	G660KD180-025
WK04 =	G660KB180-008
WK05 =	G650KE200-007
WK06 =	G650KD200-018
WK07 =	G650KB200-N10
WK08 =	G650KB200-025



**We also produce electrode caps  
in accordance with your wishes and declarations.**

We reserve the right to make changes which are in the interest of technical progress.

© by WMA Schmidt & Bittner GmbH, Baumwaide 23, D-74360 Illfeld-Auenstein, Tel. +49 7062 9066-0, Fax +49 7062 9066-20  
info@wma-sb.de or wma-sb@t-online.de, <http://www.wma-sb.de>

**Electrode caps-2**



## Holder

All cap holders are available as „dry cap“ (dc) or „wet cap“!  
Standard is „dry cap“.

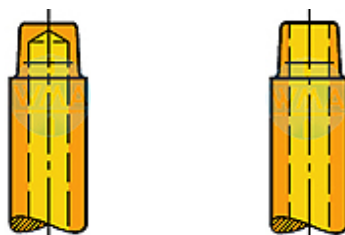

### 1) straight cap holder

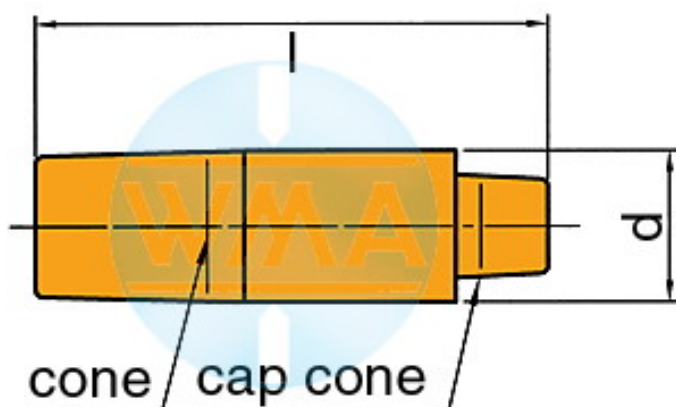

d	l (min.)	Cone	Cap cone	Order-number (dc)
12.5 mm	25 mm	1 : 10 = 12	1 : 10 = 10	G10050250-001
12.5 mm	25 mm	MK 1	1 : 10 = 10	G10090250-000
16.0 mm	30 mm	1 : 10 = 15,75	1 : 10 = 12	G10130300-001
16.0 mm	30 mm	MK 1	1 : 10 = 12	G10090300-001
18.0 mm	30 mm	1 : 10 = 17,78	1 : 10 = 12	G10060300-001
18.0 mm	30 mm	MK 2	1 : 10 = 12	G10100300-000
20.0 mm	35 mm	1 : 10 = 19	1 : 10 = 15	G10330350-000

Dimensions selected! Please provide all dimensions for non-tabular orders!

Length l available increasing upwards in 5 mm intervals.



# Electrode caps

Version: 2011-01

## 2) Pinole (cap holder) (examples extract)

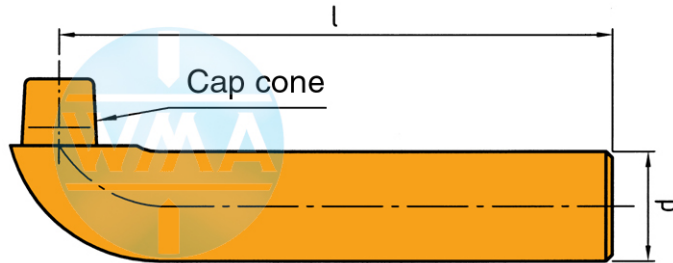

Please supply all dimensions when ordering! Model variations are available from the warehouse in varying dimensions and types! Simply ask our technical engineer.

Pinole A

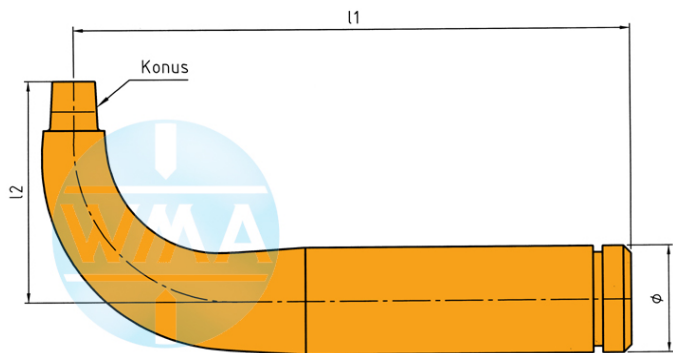

Pinole B

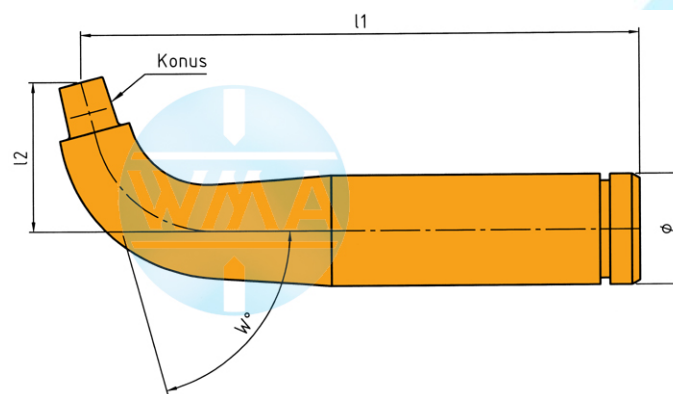

Pinole C

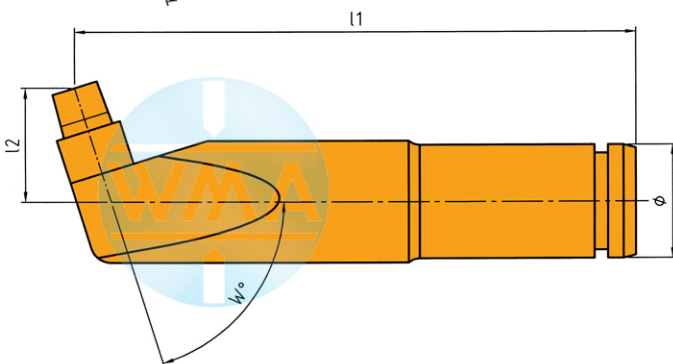

Pinole D

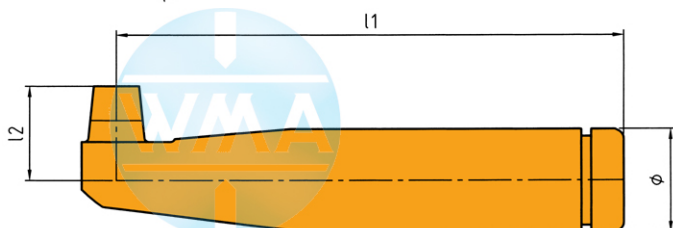

Pinole E

We reserve the right to make changes which are in the interest of technical progress.

© by WMA Schmidt & Bittner GmbH, Baumwaide 23, D-74360 Illfeld-Auenstein, Tel. +49 7062 9066-0, Fax +49 7062 9066-20  
info@wma-sb.de or wma-sb@t-online.de, <http://www.wma-sb.de>

Electrode caps-4



# Electrode caps

Version: 2011-01

## 3) Screw-in cap holder

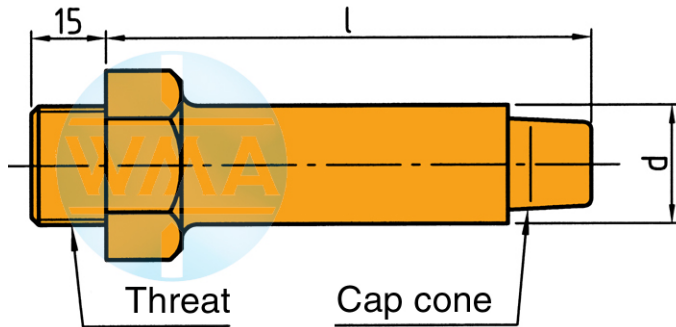

Screw-in cap holder A

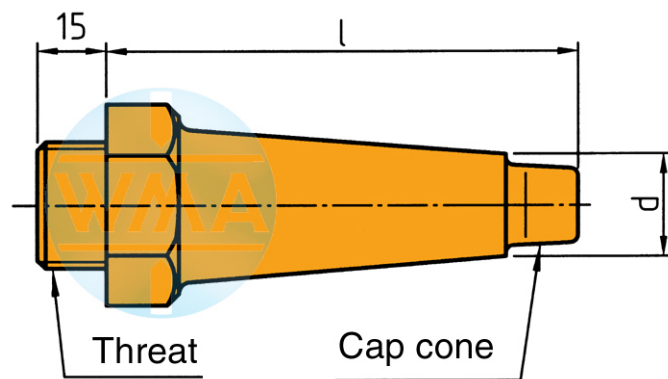

Screw-in cap holder B

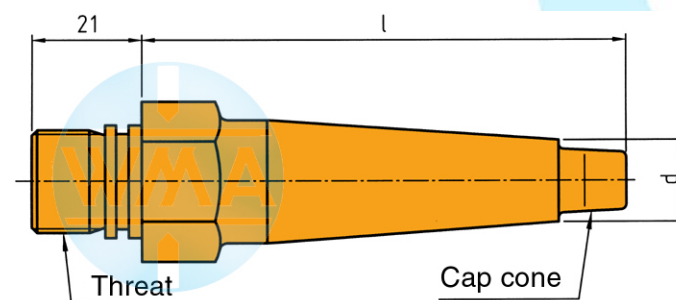

Screw-in cap holder C

Please supply all dimensions when ordering!  
Model variations are available from the warehouse in varying dimensions and types!  
Simply ask our technical engineer.



# Electrode caps

Version: 2011-01

## 4 and 5) bend cap holders

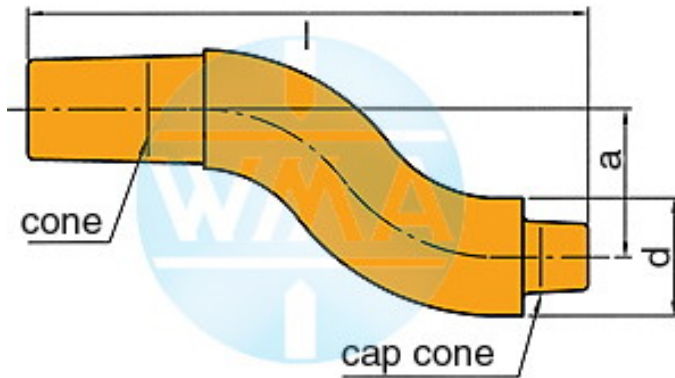

Please supply all dimensions when ordering!  
Model variations are available from the warehouse in varying dimensions and types!  
Simply ask our technical engineer.

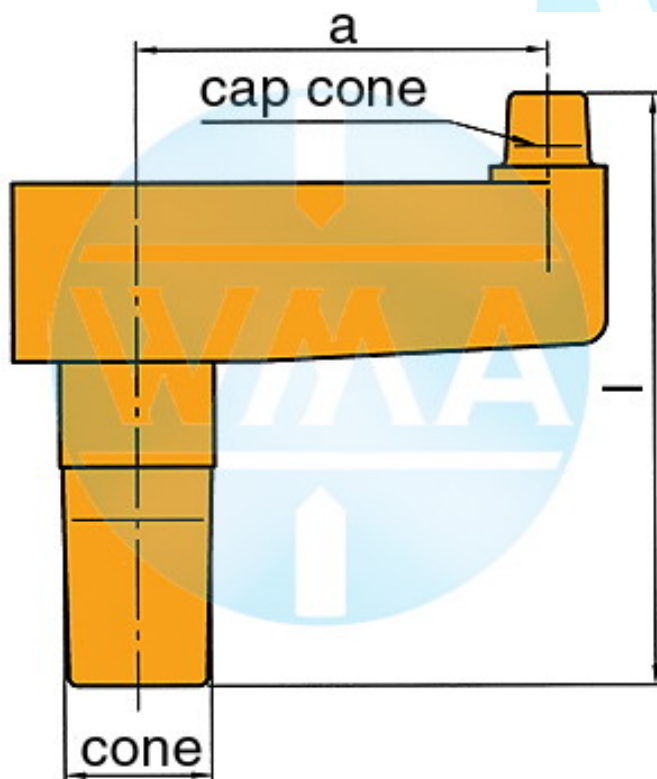

Please supply all dimensions when ordering!  
Model variations are available from the warehouse in varying dimensions and types!  
Simply ask our technical engineer.

We reserve the right to make changes which are in the interest of technical progress.

© by WMA Schmidt & Bittner GmbH, Baumwaide 23, D-74360 Illfeld-Auenstein, Tel. +49 7062 9066-0, Fax +49 7062 9066-20  
info@wma-sb.de or wma-sb@t-online.de, <http://www.wma-sb.de>

Electrode caps-6