



# Balancing units

Version: 2011-01

Balancing units are used for welding galvanized sheet metals, for tool sets and welding tools and for projection welding.

The balancing unit provides the desired balance for tool sets, used on welding presses, where electrode materials show different degrees of being worn down or where the components used are different in height.

The possible balancing distance decreases, as the desired welding pressure increases. The balancing distance lies between 6.6 and 1.8 mm.

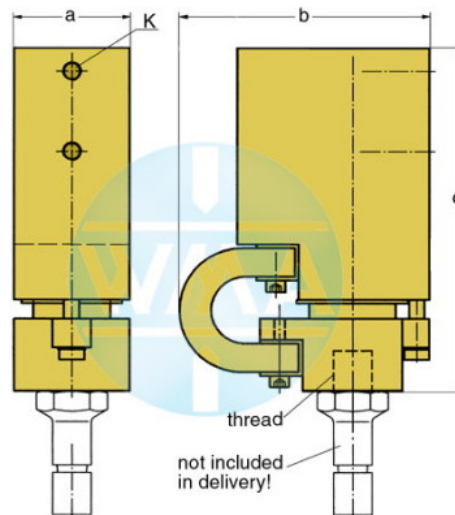

K = two cooling water connections.

Fastening:  
from above = four M10,  
from below = four M8.

Force	a	b	c	Thread	recommended value for welding current	Order-number
14 daN	25	95	100	M18 x 1.5	8 kA	XQ8.10B0014-B00
20 daN	25	95	100	M18 x 1.5	8 kA	XQ8.10B0020-B00
39 daN	25	95	100	M18 x 1.5	10 kA	XQ8.10B0039-B00
60 daN	25	95	100	M18 x 1.5	12 kA	XQ8.10B0060-B00
90 daN	25	95	100	M18 x 1.5	14 kA	XQ8.10B0090-B00
120 daN	25	95	100	M18 x 1.5	18 kA	XQ8.10B0120-B00
150 daN	25	95	100	M18 x 1.5	18 kA	XQ8.10B0150-B00
180 daN	25	95	100	M18 x 1.5	18 kA	XQ8.10B0180-B00
300 daN	35	100	100	M18 x 1.5	22 kA	XQ8.10B0300-B00
600 daN	50	125	150	M24 x 1.5	26 kA	XQ8.10D0600-B00
1200 daN	60	130	180	M24 x 1.5	30 kA	XQ8.10D1200-B00

Other dimensions and thread fixations on demand! (1 daN = 1 kg)

We reserve the right to make changes which are in the interest of technical progress.

© by WMA Schmidt & Bittner GmbH, Baumwaide 23, D-74360 Illfeld-Auenstein, Tel. +49 7062 9066-0, Fax +49 7062 9066-20  
info@wma-sb.de or wma-sb@t-online.de, <http://www.wma-sb.de>



# Balancing units

Version: 2011-01

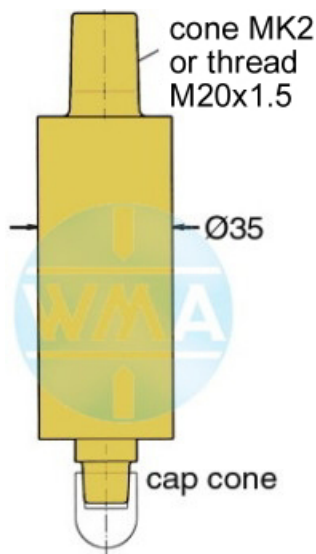

Clamping pressure	Cap cone	recommended value for welding current	Order-number with cone	Order-number with thread
200 daN	1:10=10	12 kA	XQ8.2100200-B00	XQ8.20C0200-B00
200 daN	1:10=12	12 kA	XQ8.2100200-B01	XQ8.20C0200-B01
200 daN	1:10=15	12 kA	XQ8.2100200-B02	XQ8.20C0200-B02
400 daN	1:10=10	18 kA	XQ8.2100400-B00	XQ8.20C0400-B00
400 daN	1:10=12	18 kA	XQ8.2100400-B01	XQ8.20C0400-B01
400 daN	1:10=15	18 kA	XQ8.2100400-B02	XQ8.20C0400-B02
600 daN	1:10=10	20 kA	XQ8.2100600-B00	XQ8.20C0600-B00
600 daN	1:10=12	20 kA	XQ8.2100600-B01	XQ8.20C0600-B01
600 daN	1:10=15	20 kA	XQ8.2100600-B02	XQ8.20C0600-B02

Other dimensions and thread fixations on demand! (1 daN = 1 kg)

## Special shape

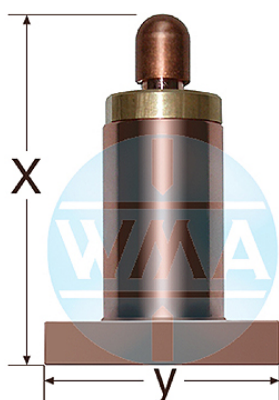

X	Y	clamping pressure
100	65	600 daN



Order-number
XQ80.100.026

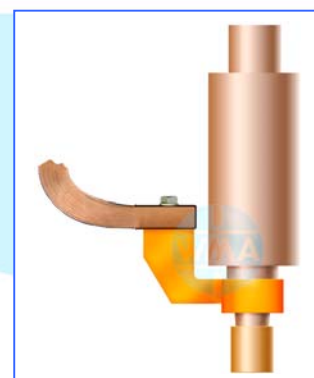

**On demand we deliver the balancing units complete mounted with flexible shunts and secondary connections.**

We reserve the right to make changes which are in the interest of technical progress.

© by WMA Schmidt & Bittner GmbH, Baumwaide 23, D-74360 Illfeld-Auenstein, Tel. +49 7062 9066-0, Fax +49 7062 9066-20  
 info@wma-sb.de or wma-sb@t-online.de, http://www.wma-sb.de



# Balancing units

Version: 2011-01

## Follow-up units for protection welding machines

Available in various sizes and dimensions,  
harmonized with your requirements!

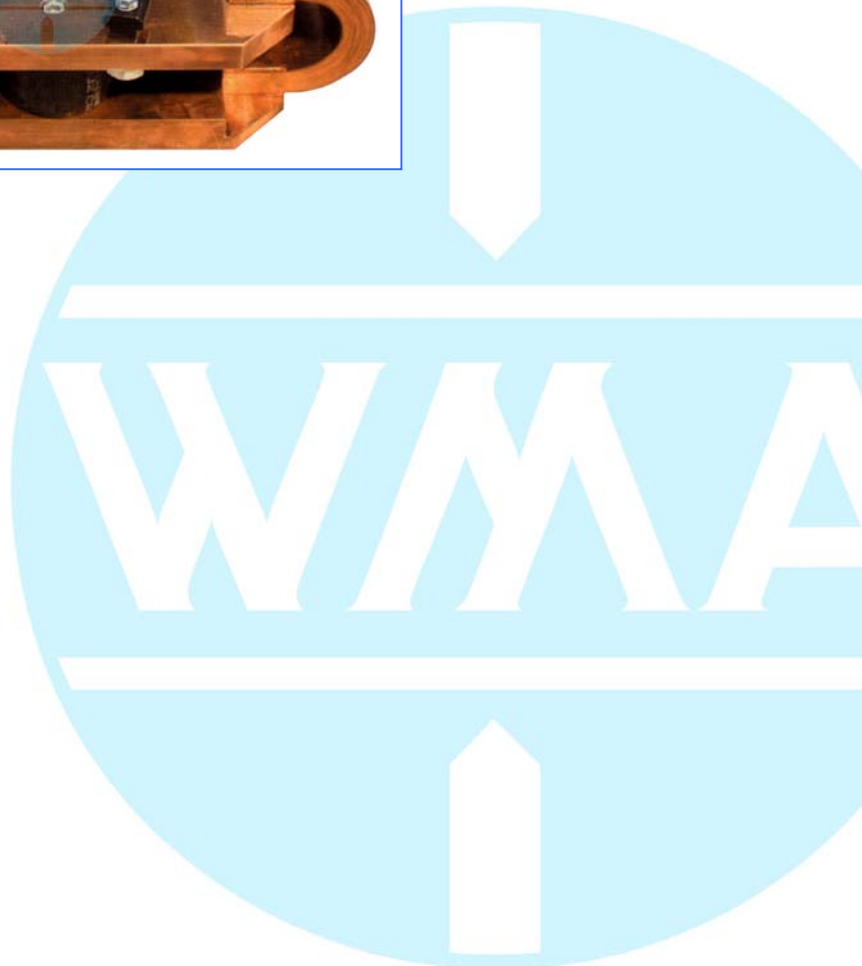

We reserve the right to make changes which are in the interest of technical progress.

© by WMA Schmidt & Bittner GmbH, Baumwaide 23, D-74360 Illfeld-Auenstein, Tel. +49 7062 9066-0, Fax +49 7062 9066-20  
info@wma-sb.de or wma-sb@t-online.de, <http://www.wma-sb.de>

**Balancing units-3**