



TPMP 5-1/20-90

Version: 01-2011

Pneumatically operated, water cooled* table spot welding machines in compact design

- single stroke mechanism
- with an attached compressed air maintenance unit
- one cylinder chamber can be switched off
- with a machine table and side rests
- with foot switch
- 3 meters power supply cable

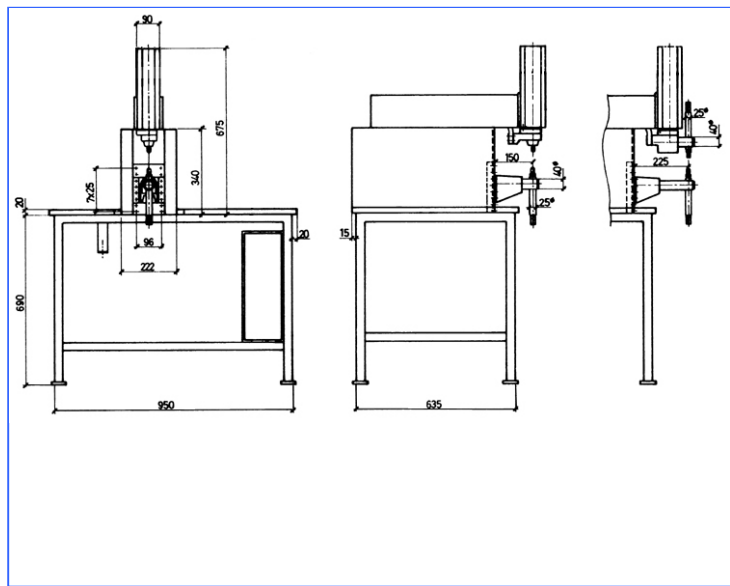

| | TPMP 5/20 | TPMP 5/35 | TPMP 5-1/36 | TPMP 5-1/90MF** |
|----------------------|--------------------|--------------------|--------------------|--------------------|
| Welding performance* | 2.5 + 2.5 mm | 3 + 3 mm | | |
| Nominal capacity | 20 kVA (at 50% ED) | 35 kVA (at 50% ED) | 36 kVA (at 50% ED) | 90 kVA (at 20% ED) |
| Supply power | 66.0 kVA | 100.8 kVA | | |
| Connection section | 16 mm ² | 25 mm ² | | |
| Fuse, delayed action | 63 A | 100 A | | |
| max. welding current | 17.9 kA | 23.6 kA | | |
| Electrode force | 550 daN | 550 daN | 550 daN | 550 daN |
| Depth of throat | 150 mm | 150 mm | 295 mm | 295 mm |
| Arm spacing | | | 200 mm | 200 mm |
| Electrode stroke | 40 mm | 40 mm | 75 mm | 75 mm |
| Order-number | XL0.111.C01 | XL0.117.C00 | XL0.118.100 | XL0.130.C00 |

* The max. welding values quoted refer to sheet steel.

** MF = Mid frequency technology.

Standard design

Different welding controls can be used.

*This kit does not include a water chiller!

WMA is general distributor for NIMAK welding machines in Baden-Wuerttemberg.

We reserve the right to make changes which are in the interest of technical progress.

© by WMA Schmidt & Bittner GmbH, Baumwaide 23, D-74360 Illfeld-Auenstein, Tel. +49 7062 9066-0, Fax +49 7062 9066-20
info@wma-sb.de or wma-sb@t-online.de, http://www.wma-sb.de

TPMP5-1



TPMP 5-1/20-90

Version: 01-2011

**Options,
the following devices and equipments can be built on:**

Flow controls

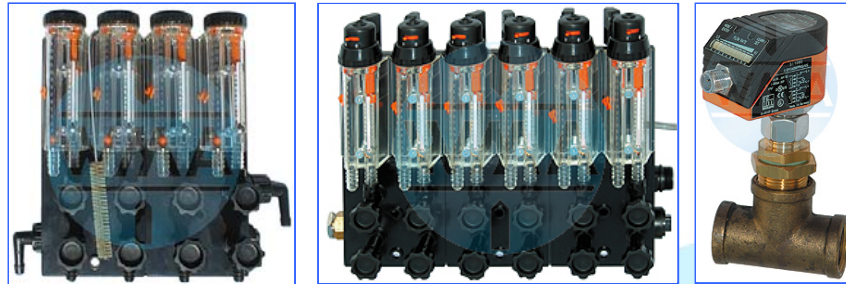

Pressure measuring instruments

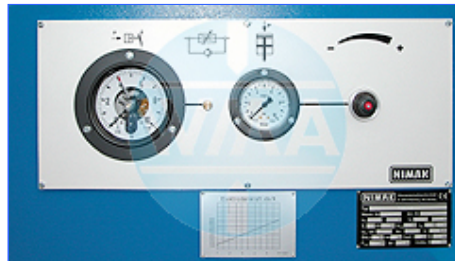

Water filter



Mounted electrode holder

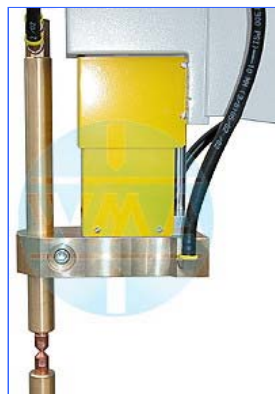

Supply cylinder with hand wheel



We reserve the right to make changes which are in the interest of technical progress.

© by WMA Schmidt & Bittner GmbH, Baumwaide 23, D-74360 Illfeld-Auenstein, Tel. +49 7062 9066-0, Fax +49 7062 9066-20
info@wma-sb.de or wma-sb@t-online.de, <http://www.wma-sb.de>

TPMP5-2